



09

ECO-DESIGN®

L I G H T A U T H O R

Who is ... **ECO-DESIGN**

EN / ECO-DESIGN, producer of design light fittings was established in 1996. The company is nowadays successfully represented in 20 countries and presents its products at exhibitions in Frankfurt am Main, Milano, Prague, Tokio and Dubai.

When creating new designs ECO-DESIGN works with ecological materials such as aeroceramics, ecolit, porcelaine or special plaster and uses world-renowned electrocomponents to produce original high-quality luminaires for the most demanding clients.

ECO-DESIGN team consists of designers, production engineers, technologists, lighting specialists, workers and traders. The company offers to its business partners full service from project to its realization – proposals, calculations, control systems, technical and marketing trainings leading to development and support of mutual cooperation.

CZ / ECO-DESIGN je výrobce designových svítidel, založený v roce 1996. V současné době vyváží svítidla do 20 zemí a prezentuje své produkty na výstavách ve Frankfurtu nad Mohanem, Milanu, Praze, Tokiu a Dubaji.

Firma při výrobě svých svítidel využívá ekologických materiálů jako je aerokeramika, ekolit, porcelán nebo speciální sádra. Spolupracuje se světovými výrobci elektrokomponentů tak, aby vznikla kvalitní a originální svítidla pro nejnáročnější klientelu.

Náš tým se skládá z designerů, technologů, světelných techniků, pracovníků ve výrobě a obchodníků. Společnost nabízí pro své obchodní partnery plný servis od projektu až po realizaci - návrhy, výpočty, řízení osvětlení, technická a marketingová školení o svých výrobcích, směřující k rozvoji a podpoře vzájemného obchodu.



DE / ECO-DESIGN ist ein Designbeleuchtungshersteller, im Jahre 1996 gegründet. Zur Zeit wird Beleuchtung in 20 Staaten exportiert und die Produkte werden auf den Messen in Frankfurt am Main, Mailand, Prag, Tokio und Dubai präsentiert.

Die Firma nutzt bei der Herstellung ihrer Beleuchtung ökologisches Material wie Aerokeramik, Ekolith, Porzellan oder speziellen Gips. Sie arbeitet mit Weltbekannten Herstellern von Elektrokomponenten so zusammen, dass Qualitäts- und Originalbeleuchtung für anspruchsvollste Klientel entstehen können.

Unser Team besteht aus Designern, Technologen, Lichttechnikern, Arbeitern in der Fertigung und Geschäftsleuten. Die Gesellschaft bietet ihren Geschäftspartnern vollen Service von Projekten bis zur Realisierung - Entwürfe, Berechnungen, Steuerung der Beleuchtung, organisiert technische und marketingbezogene Schulungen über die eigenen Produkte, die zur Entwicklung und Unterstützung des gegenseitigen Geschäfts hinausgehen.

FR / ECO-DESIGN est un fabricant de luminaires design, fondé en 1996. Récemment, il exporte ses luminaires dans vingt pays du monde et présente ses produits aux expositions de Frankfurt am Main, Milan, Prague, Tokio et Dubai.

Pendant le développement des projets pour ses luminaires, l'entreprise utilise les matériaux écologiques tels que l'aéro-céramique, écolith, porcelaine ou le plâtre spécial. Elle coopère également avec les producteurs mondiaux de composants électriques afin de fabriquer des luminaires originaux et de qualité et répondre ainsi aux besoins des clients les plus exigeants.

Notre équipe est composée de designers, ingénieurs, techniciens lumière, d'unité de la production et vendeurs. La société garantit le service complet pour ses partenaires commerciaux au début du projet jusqu'à sa réalisation – projets, calculs, régulation du luminaire, la formation technique et marketing de ses produits permettant le développement et le soutien réciproque entre les deux parties.

RU / ECO-DESIGN является фирмой, которая производит дизайнерские светильники. Она была основана в 1996 году. В настоящее время фирма экспортирует лампы в двадцать стран мира и представляет свою продукцию на выставках во Франкфурте на Майне, Милане, Праге, Токио и Дубаи.

При разработке своих светильников компания использует экологические материалы, такие, как аэрокерамика, эколит, фарфор или специальный гипс. Сотрудничество с международными производителями электрокомпонентов обеспечивает производство качественных и оригинальных светильников для самых требовательных клиентов.

Наша команда состоит из дизайнеров, технологов, техников освещения, людей, работающих в сфере производства и бизнеса. Компания предлагает своим бизнес-партнерам полный комплекс услуг от проектирования до реализации – разработки проектов, расчеты, контроль освещения, технический и маркетинговый инструктаж по продукции, что способствует развитию и продвижению взаимного бизнеса.

Designers



Bořek Šípek

Olgoj Chorchoj

Pavel Knapěk

Jiří Pták

Miroslav Oliva

Alexander Dubský

Artline Exclusive Author Design
 Exkluzivní autorský design / Exklusives Urheberdesign
 Design exclusif d'auteur / Эксклюзивный авторский дизайн



06 Page

Aeroline Porcelain Lights
 Porcelánová svítidla / Porzellanleuchten
 Luminaires en porcelaine / Фарфоровые светильники



16

Whiteline Plaster Lights
 Sádrová svítidla / Gipsleuchten
 Luminaires en plâtre / Гипсовые светильники



22

Silverline Stainless Steel Lights
 Nerezová svítidla / Edelstahlleuchten
 Luminaires Inox / Светильники из нержавеющей стали



64

Longline Light Cornices
 Sádrové světelné římsy / Gipsleuchtgesims
 Moulures lumineuse en plâtre / Гипсовые карнизы-светильники



78

TechnicalData Symbols, Lightsources, Eulumdata, Index by Code 88
 Symboly, eulumdata, světelné zdroje, seznam podle kódů / Symbole, Eulumdata, Leuchtmittel
 Symboles, Eulumdata, Source lumineuse / Символы, Источники света, Индекс по коде

MarketingTools Marketingové nástroje / Marketinginstrumente / Outils marketing / Маркетинговые инструменты 94

Index by name

Name	Page	Name	Page	Name	Page	Name	Page
A100	48	D109	35	K147	52	S1	55
A101	48	D156	35	K158	52	S2	55
A102	48	D159	35	Kappa	80	S6	55
AD101	48	DR508	82			S9	55
AKG173	47	DRD508	82	Lambda	80	S10	55
AR308	82	DS109	34	LightLAB Desk	10	S11	55
Anna P	13	Darboka	21	LightLAB Floor	11	SA148	56
Anna Pavlovna	13	De La Rose	15	Leader R	62	SA149	56
Arctic	08	Disc	26	Leader S	62	SP74	57
Arctic Long	09	Disc V129	27	LED Info	76	ST123	38
Arsenal	12	Disc V153	27			ST126	38
		Drum	18	M145	51	ST127	38
B104	48			Marina	28	STZ123	39
B105	48	E110	51	Milano 1	70	STZ126	39
BR408	82	E125	51	Milano 2	70	STZ127	39
Bat	18	Eta	80	Milano S	70	SY135	56
Big Sun	14					SY136	56
Bologna B	71	Filigran	14	N143	52	SY137	56
Bologna S	71	Filler 1	46	NS143	52	SYP136	57
Bolt	34	Filler 2	46	Navy 1	28	SYJ137	57
Bowl	30	Flute D1	58	Navy 2	28		
		Flute D2	58	Navy 3	28	Scarf	12
C106	50	Flute D3	58			Squares	20
C107	50	Flute U1	59	O120	29	Stairs	49
CD106	50	Flute U2	59	O150	29	Spider	15
CD107	50	Flute U3	59	Oboe D1	60		
CR108	82	Flute V1	58	Oboe D2	60	T144	53
CRT108	82	Flute V2	58	Oboe D3	60	Torino1	66
Chic A	32	Flute V3	58	Oboe U1	61	Torino2	66
Chic S	32	Frame O	42	Oboe U2	61	Torino3	66
Chic SQT2000	36	Frame S	42	Oboe U3	61		
Chic SQ122	44			Oboe V1	60	U128	53
Collar	30	GL112	47	Oboe V2	60		
Conga	18	GP112	47	Oboe V3	60	Venezia 18	72
Cymbals	21	Grip 1	40			Venezia 30	72
		Grip 2	40	PR208	82	Venezia 50	72
		Grip 3	40	PikoLED	83	Venezia LED 8	73
						Venezia LED 15	73
		H113	31	Q142	34	Venezia LED 20	72
		H151	31	Q155	34	Venezia UP 20	72
		H152	31	QND142	34	Venezia UP 35	72
		H168	31	QND155	34	Venezia UP 50	72
		HE152	31	QR608	82	Verona 20	74
		HS113	31			Verona 34	74
		Halfdrum 1	19	RA102	54	Verona 54	74
		Halfdrum 2	19	RT133	54	Verona LED 9	75
				Roma 1	68	Verona LED 16	75
		I114	51	Roma 2	68	Verona UP 20	74
		I157	51	Roma 3	68	Verona UP 35	74
				Roma 4	68	Verona UP 50	74
		JR333	81	Roma Mini	69	Z163	54

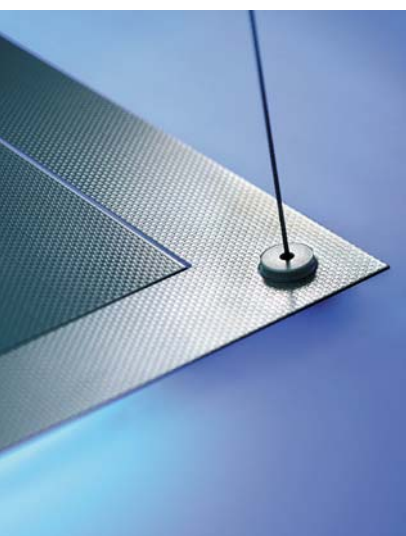

Artline

Artline



Arctic

08 Page



Arctic Long

09

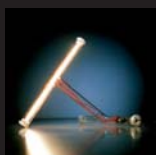

LightLAB Desk

10



LightLAB Floor

11

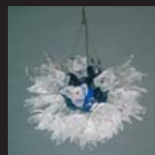

Arsenal

12 Page



Scarf



Anna Pavlovna

13



Anna P



Big Sun

14



Filigran

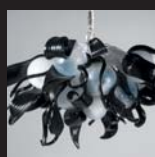

Spider

15



De La Rose

EN / When perfect material meets precise work and czech tradition of good products the result is Artline. Production line just for you, our most demanding clients. We wish you good time spent in the company of Artline.

CZ / Když se potká skvělý materiál s precizním zpracováním a českou tradicí dobrého výrobku, vznikne Artline. Řada svítidel právě pro Vás, naše nejnáročnější zákazníky. Přejeme Vám příjemné chvíle, strávené ve společnosti Artline.

DE / Wenn sich unser tolles Material mit präziser Bearbeitung und der Tschechischen Tradition eines guten Erzeugnisses paaren, entsteht Artline. Eine Leuchtenreihe für Sie, unsere anspruchsvollsten Kunden. Wir wünschen Ihnen angenehme Momente, die Sie in Gesellschaft von Artline verbringen.

FR / Quand les matériaux d'excellente qualité rencontrent le travail précis et la tradition tchèque du bon produit, Artline est né. La série de luminaires pour vous, nos clients les plus exigeants. Nous vous souhaitons des moments agréables en compagnie d'Artline.

RU / Когда превосходный материал сталкивается с безукоризненной обработкой и чешской традицией хороших изделий, возникает Artline. Линия дизайнерских светильников для Вас, наших самых требовательных клиентов. Мы желаем Вам приятно провести время в компании Artline.

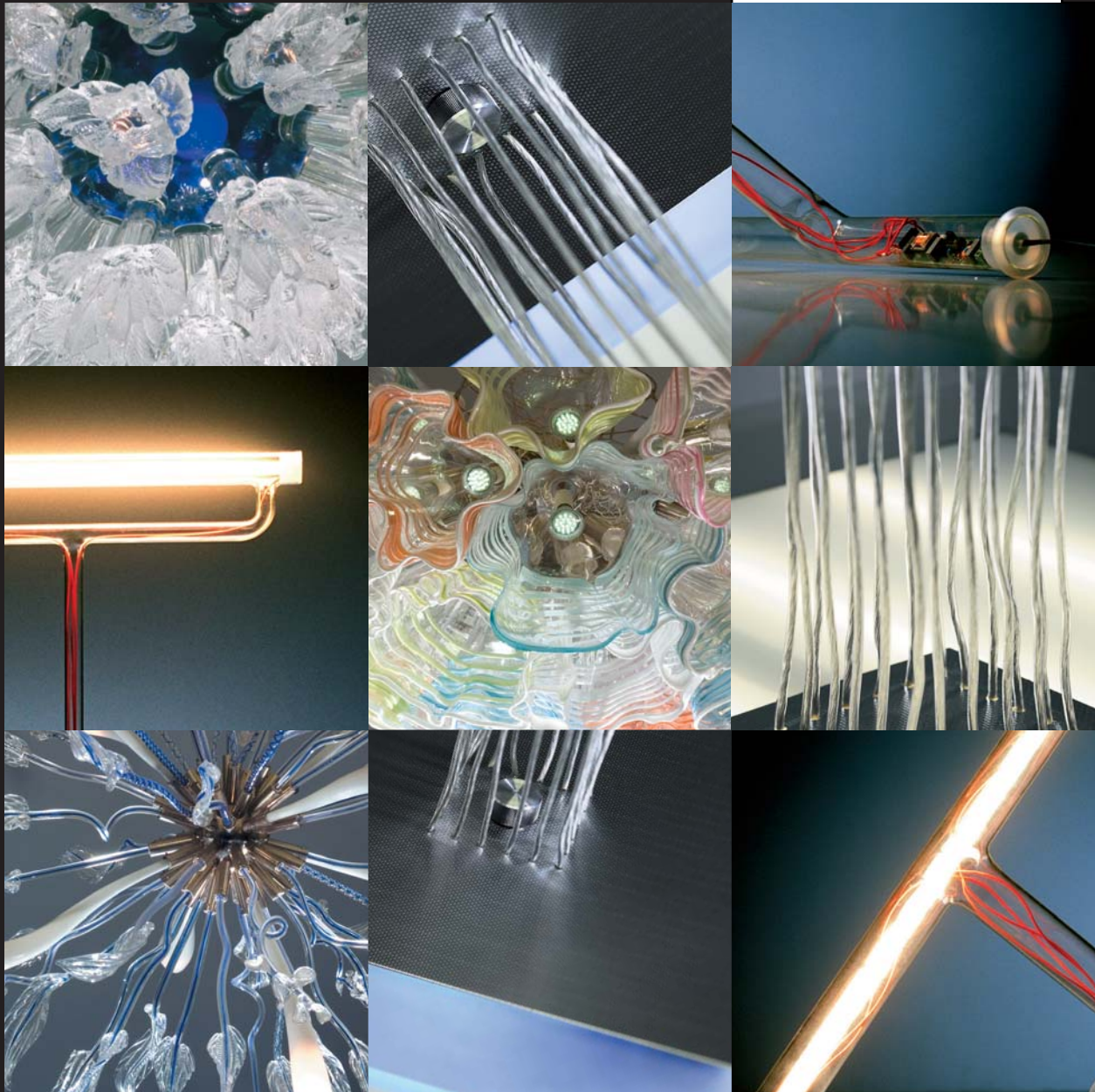

Material unlimited author design. The most modern technologies. Precise work. Hand made.

Materiálově neomezený autorský design. Nejmodernější technologie. Precizní zpracování. Ruční práce.

Material bez omezení nebeschränktés Urheberdesign. Modernste Technologie. Präzise Bearbeitung. Handarbeit.

Le design d'auteur avec un choix illimité de matériaux. Les technologies les plus modernes. Le travail précis. Travail manuel.

Авторский дизайн, не ограниченный материалом. Новейшие технологии. Безукоризненная обработка. Ручное дело.

Arctic

CODE 4630 +  LED

4 x 11W, T2, W 4,3x8,5d, EVG + LED, 16W/230V     

CODE 4631

4 x 11W, T2, W 4,3x8,5d, EVG + LED RGB, 16W/230V

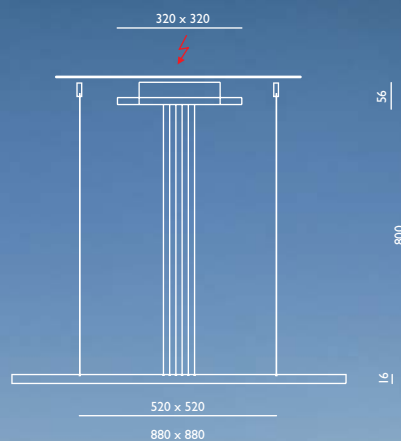

Design by Alexander Dubský



Design by Alexander Dubský
 Top Light Award, Pragointerier 2009



Arctic Long

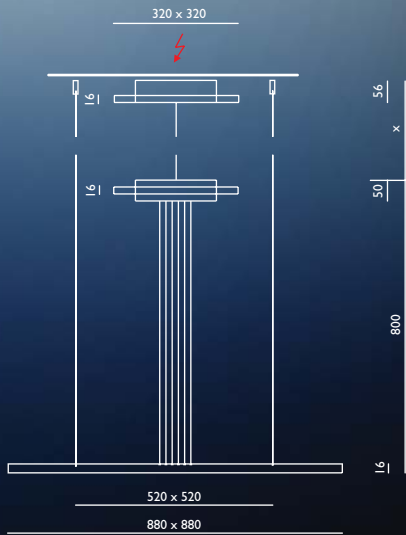

CODE 4632 + LED

4 x 11W, T2, W 4,3x8,5d, EVG + LED, 16W/230V W ■ B ■ G ■ Y ■ R ■

CODE 4633

4 x 11W, T2, W 4,3x8,5d, EVG + LED RGB, 16W/230V



LightLAB Desk

CODE 5002

8W, T5, G5, EVG

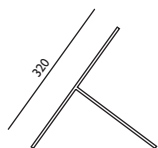

LightLAB Floor

CODE 5001

24W, T5, G5, EVG

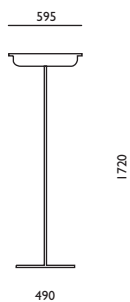



Design by Olgoj Chorchoj



Design by Bořek Šípek

Arsenal

CODE 5501 100W, E27

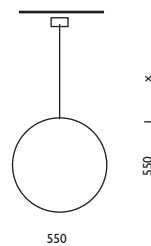

Scarf

CODE 5502 height / výška 430 mm



Design by Bořek Šípek

Anna Pavlovna

CODE 5503 40 x LED 0,8W/230V, E14
min 40 pcs / ks

CODE 5504 40 x 20W, E14
min 40 pcs / ks

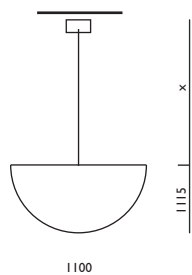

Anna P

CODE 5505 height / výška 440 mm

Artline



Design by Bořek Šípek

Big Sun

CODE 5508 6 x 20W/12V, G4
6-12 pcs / ks

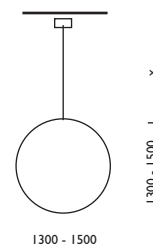

Design by Bořek Šípek



Filigran

CODE 5509 height / výška 600 mm



Design by Bořek Šípek



Spider

CODE 5510 9 x 60W, E27
min 9 pcs / ks

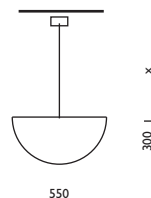

De La Rose

CODE 5511 height / výška 450 mm

Aeroline

Aeroline



Bat

18 Page



Drum

18 Page

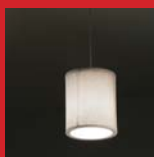

Conga

18



Halfdrum 1

19



Cymbals

21



Halfdrum 2

19

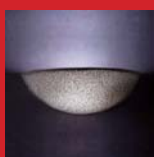

Darboka

21



Squares

20

EN / Looking at the airy material we fall in love with it at first sight. Rays of light refract the inner structure of this inimitable material and create unique atmosphere.

CZ / Při pohledu na vzdušný materiál se do něj na první pohled zamilujeme. Světelné paprsky se lámou o vnitřní strukturu tohoto nenapodobitelného materiálu a vytvářejí ojedinelou atmosféru.

DE / Bei der Betrachtung des luftigen Materials verlieben wir uns auf den ersten Blick. Die Lichtstrahlen brechen an der inneren Struktur dieses unnachahmlichen Materials und schaffen eine einzigartige Stimmung.

FR / Vous allez tomber sous le charme du premier coup d'œil. Les rayons lumineux se réfractent dans la structure d'intérieur de ces matériaux inimitables, créant ainsi une ambiance exceptionnelle.

RUS / При взгляде на воздушный материал влюбляетесь в него с первого взгляда. Световые лучи преломляются от внутренней структуры этого неподражаемого материала и создают неповторимую атмосферу.



Special burnt ceramic. Duplex opal glass. Safety glass. Stainless steel.

Speciální pálená keramika. Sklo Duplex opál. Stratobel. Nerezová ocel.

Spezielle gebrannte Keramik. Duplexglas Opal. Stratobel. Edelstahl.

La céramique cuite spéciale. Le verre Duplex brûlure. Stratobel. Inox.

Специальная обожженная керамика. Стекло дуплекс опал. Стратобел. Нержавеющая сталь.



Bat



Design by Alexander Dubský

CODE 4567

max 100W, SOFT GLOBE G95, E27

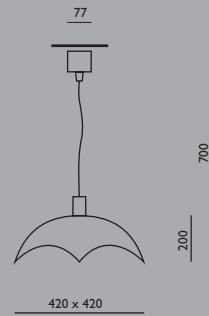

Conga



CODE 4520

max 75W, T60 SOFT, E27

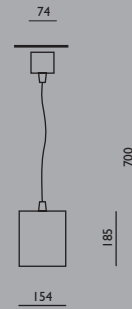

Drum



CODE 4550

22W + 40W, TL-5C, 2Gx13, EVG

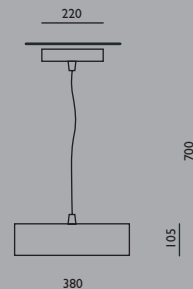



Halfdrum 1

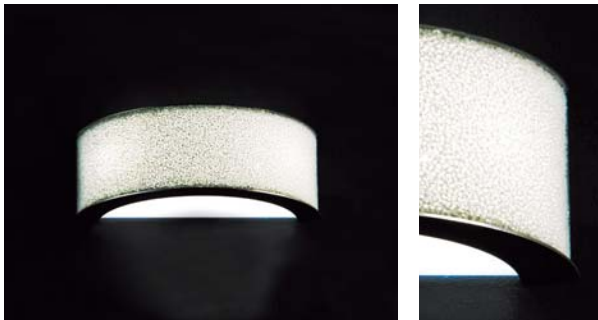

CODE 4401

2 x max 25W, G9

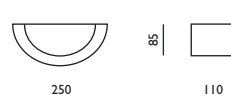

Halfdrum 2



CODE 4402

2 x max 25W, G9

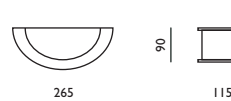

Design by Alexander Dubský

Squares



Design by Alexander Dubský

CODE 4540 22W, TL-5C, 2Gx13, EVG + max 75W/230V, ES 63, GU10
4541 22W, TL-5C, 2Gx13, EVG + Power LED 3W/230V, GU10

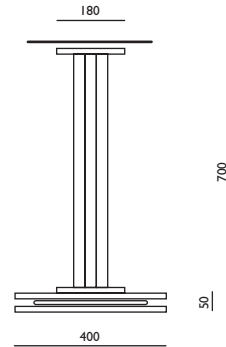

 **A** **4,7 kg** **IP20**  **A?B** **K**



CODE 4530 22W, TL-5C, 2Gx13, EVG + max 75W/230V, ES 63, GU10
 4531 22W, TL-5C, 2Gx13, EVG + Power LED 3W/230V, GU10



Design by Alexander Dubský

A
4,1 kg
IP20

A?B
K

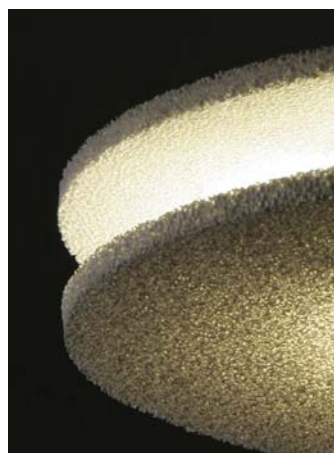
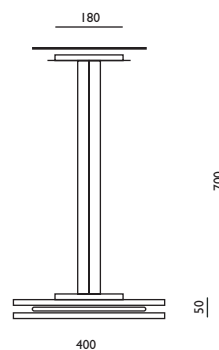

Darboka

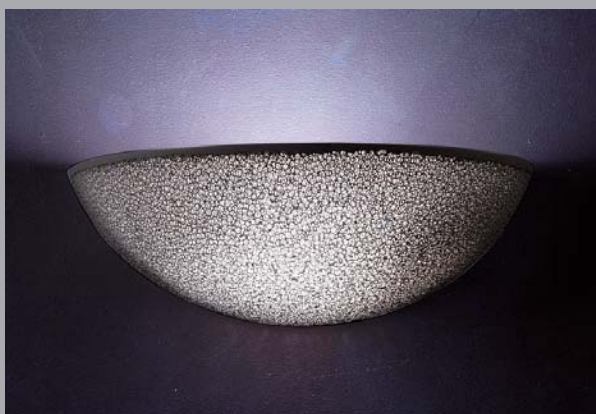

CODE 4421
 max 60W, A45, E27



A
0,8 kg
IP20

Whiteline

Whiteline



Bowl

30 Page



Frame series

42 Page



Collar

30



Marina

28



Chic A

32



Navy series

28



Chic S

32



SQ122

44



Disc

26



ST series

38



Grip series

40

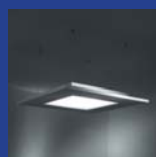

STZ series

39

EN / In harmony with your home. It will help you to find answers to questions what, where and how. Simplicity of the line enters the space with an ease of light and shade. Naturally. You can adapt it to the colour and mood of the space. Whiteline is here for you.

CZ / Splyne s domem. Pomůže Vám nalézt odpovědi na otázky co, kam a jak. Jednoduchost řady vstoupí do prostor s pouhou lehkostí světla a stínu. Přirozeně. Můžete ji barevně přizpůsobit náladě prostoru. Whiteline je tu pro Vás, aby se přizpůsobila.

DE / Es verschmilzt mit dem Haus. Es hilft Ihnen die Antworten auf Fragen zu finden, was, wohin und wie. Die Einfachheit der Reihe tritt in einen Raum mit bloßer Leichtigkeit des Lichts und des Schattens ein. Natürlich. Sie können sie farblich der Stimmung des Raumes anpassen. Whiteline ist hier für Sie, um sich anzupassen.

FR / Elle s'adapte à votre maison. Elle vous aide à trouver les réponses aux questions quoi, où et comment. La simplicité de la série s'intègre dans l'espace avec la légèreté de la lumière et de l'ombre. Naturellement. Vous pouvez en modifier selon ses couleurs dans la nature de l'espace. Whiteline est là pour vous afin de répondre à vos exigences.

RUS / Сольется с домом. Поможет вам найти ответы на вопросы что, где и каким образом. Простота линии впишется в помещение с помощью всего лишь света и тени. Естественно. Легко приспосабливается к оттенку стен помещения. Whiteline создана для того, чтобы адаптироваться.



Ecolit. Natural hardened plaster. Triplex opal glass. Safety glass. Stainless steel.

Ekolit. Přírodní tvrzená sádra. Sklo Triplex opál. Stratobel. Perspex. Nerezová ocel.

Ecolit. Natürlicher Hartgips. Triplexglas Opal. Stratobel. Perspex. Edelstahl.

Ecolith. Le plâtre durci à la base naturelle. Verre Triplex brûlure. Stratobel. Perspex. Inox.

Эколит. Естественно упрочненный гипс. Стекло триплекс опал, Стратобел. Нержавеющая сталь.

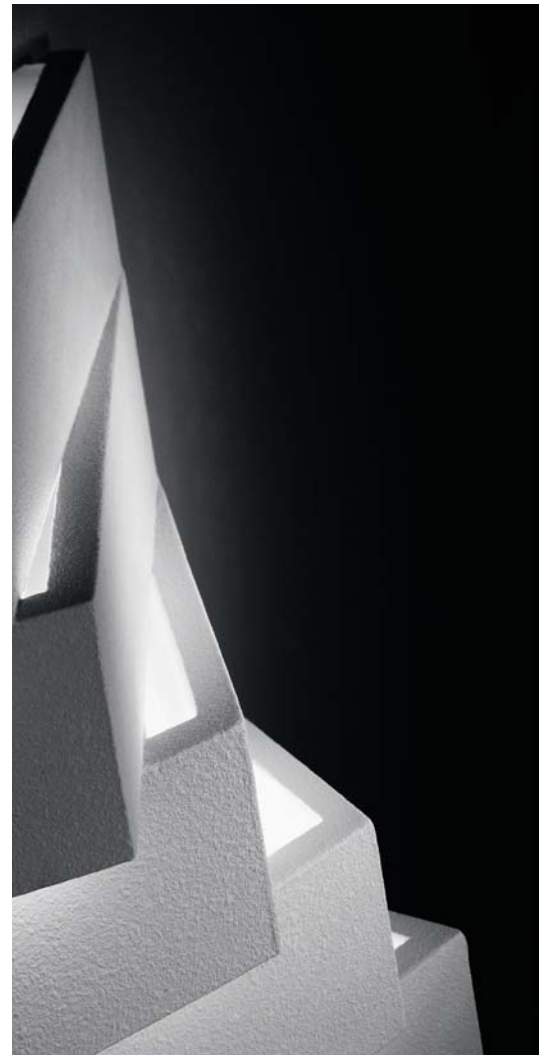

White**line**

White**line**



A / AD series 48



AKG 47



B series 48



C / CD serie 50



D / DS serie 35



E series 51



Filler series 46

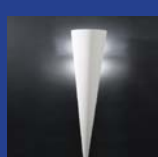

Flute series 58



G series 47



H series 31

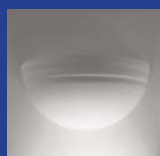

I series 51



K series 52



Leader series 62



M 51



N series 52



O series 29



Oboe series 60



Q / QND series 34



R series 54



SA / SY series 56



Spot series 55



Stairs 49



T 53



U 53



V series 27



Z 54

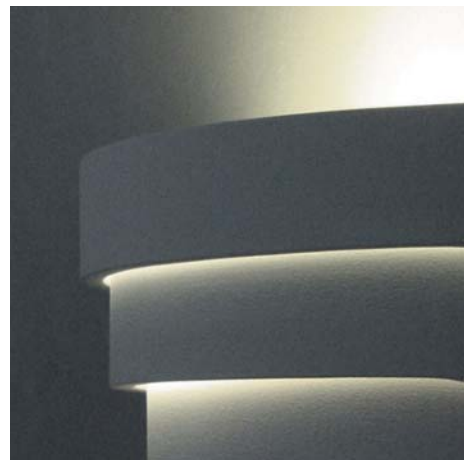
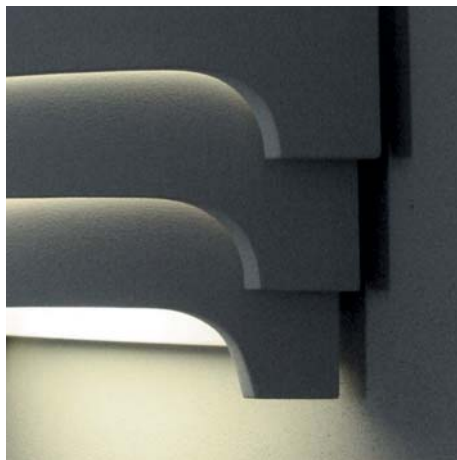

White^{line}

Disc



CODE 4600

22 + 40W, TL-5C, 2Gx13, EVG

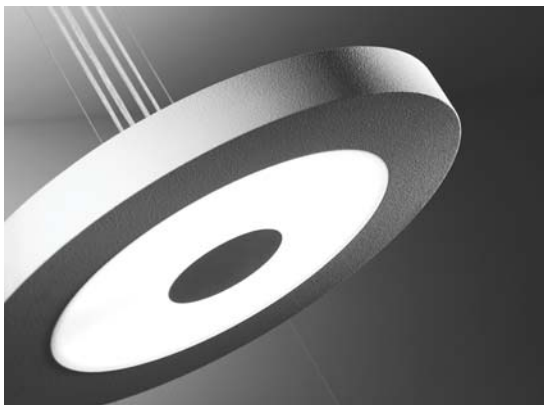
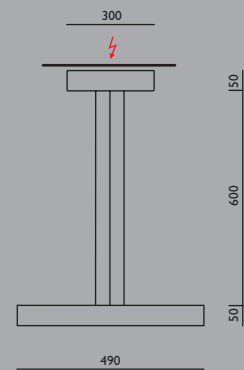

Design by Alexander Dubský

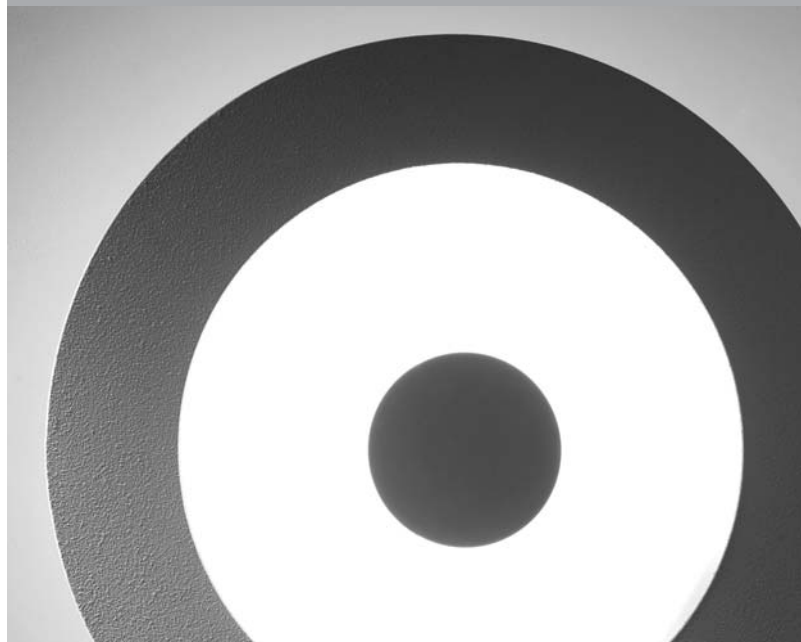



V series

V129

2,6 kg

CODE 1390
CODE 1391
CODE 1392
CODE 1393

max 100W, A60, E27
max 100W, A60, E27 +
10W, TC-DEL, G24q-1, EE
2 x max 100W, A60, E27
2 x max 23W, TC-TSE, E27

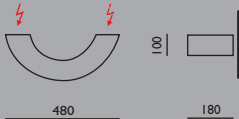

V153

1,1 kg

CODE 1395
CODE 1396

max 60W, A45, E27
max 15W, TC-TSE, E27



White line

Marina



Marina

7,0 kg

CODE	1582	2 x 60W, A45, E27
	1583	2 x 23W, TC-TSE, E27
	1584	2 x 42W, TC-TEL, Gx24q-4, EVG

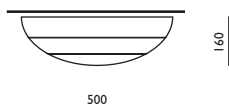
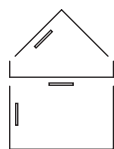

Navy series



Design by Jiří Pták

Navy 1

11 kg

CODE	1593	3 x 60W, A45, E27
	1594	3 x 23W, TC-TSE, E27
	1595	2 x 36W, TC-F, 2G10, DIM ECO
	1596	2 x 36W, TC-F, 2G10, DIM EXCEL

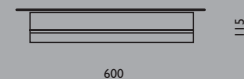

Navy 2

4,4 kg

CODE	1800	2 x 60W, A45, E27
	1801	2 x 15W, TC-TSE, E27
	1802	2 x 26W, TC-DEL, G24q-3, EVG

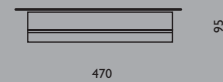

Navy 3

1,8 kg

CODE	1803	max 60W, A45, E27
	1804	13W, TC-DEL, G24q-1, EVG

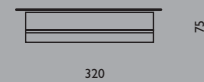



0 series



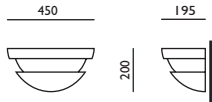

0120 CODE **2,8 kg**

- 1320 max 100W, A60, E27
- 1321 max 23W, TC-TSE, E27 
- 1322 26W, TC-D, G24d-3, KVG 



0150 CODE **1,0 kg**

- 1330 max 60W, A45, E27
- 1331 26W, TC-D, G24d-3, KVG 
- 1332 26W, TC-DEL, G24q-3, EVG 









Bowl



CODE

1233 max 60W, A45, E27

1234 26W, TC-T, G24d-3, KVG 

1254 26W, TC-TEL, G24q-3, EVG 



P

C

1,9 kg

IP20



Collar



CODE

1263 max 60W, A45, E27

1264 max 23W, TC-TSE, E27 

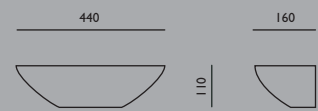

P

C

1,9 kg

IP20



Design by Jiří Pták

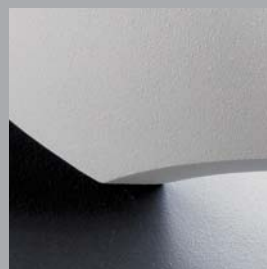

H series

ECO-DESIGN



H113 **2,4 kg**

- 1235 max 100W, E27, A60
 1236 max 23W, TC-TSE, E27
 1237 max 150W, QT-DE12, 114,2 mm, R7s
 1238 75W, HIT-DE, Rx7s
 1240 150W, QT-DE12, 114,2 mm, R7s + 75W, HIT-DE, Rx7s
 1242 26W, TC-D, G24d-3, KVG
 1243 26W, TC-D, G24d-3, KVG, EE
 1246 2 x 26W, TC-DEL, G24q-3, EVG
 1247 2 x 26W, TC-DEL, G24q-3, EVG, EE



HS113 **2,3 kg**

- 1250 max 100W, A60, E27
 1251 max 23W, TC-TSE, E27
 1253 42W, TC-TEL, Gx24q-4, EVG



H152 **4,6 kg**

- 1200 2 x max 100W, A60, E27
 1201 2 x max 23W, TC-TSE, E27
 1202 max 150W, QT-DE12, 114,2 mm, R7s
 1203 75W, HIT-DE, Rx7s
 1204 150W, HIT-DE, Rx7s-24
 1205 150W, QT-DE12, 114,2 mm, R7s + 75W, HIT-DE, Rx7s
 1206 150W, QT-DE12, 114,2 mm, R7s + 150W, HIT-DE, Rx7s
 1213 36W, TC-L, 2G11, EVG
 1214 36W, TC-L, 2G11, EVG, EE

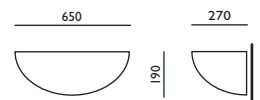

HE152 **4,6 kg**

- 1220 2 x max 100W, A60, E27
 1221 2 x max 23W, TC-TSE, E27
 1225 36W, TC-L, 2G11, KVG

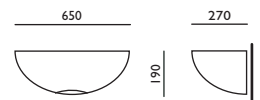

H151 **1,8 kg**

- 1230 max 60W, E27, A45
 1231 26W, TC-D, G24d-3, KVG
 1232 100W, QT-DE12, 74,9 mm, R7s
 1226 26W, TC-DEL, G24q-3, EVG

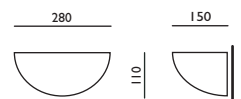

H168 **2,4 kg**

- 1260 max 60W, A45, E27
 1261 max 23W, TC-TSE, E27
 1262 150W, QT-DE12, 114,2 mm, R7s



Chic series

Chic A

CODE

1760	2 x 39W, T5, G5, EVG
1761	4 x 39W, T5, G5, EVG
1762	4 x 39W, T5, G5, DIM ECO
1763	4 x 39W, T5, G5, DIM EXCEL
1764	4 x 39W, T5, G5, DIM ANALOG 1-10V

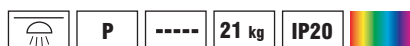
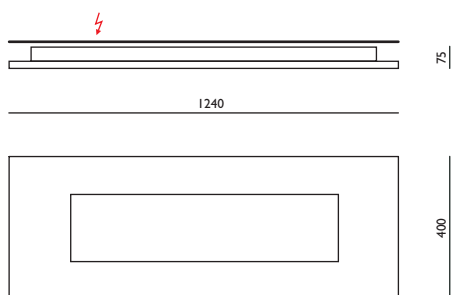

Chic S

CODE

1750	2 x 39W, T5, G5, EVG
1751	4 x 39W, T5, G5, EVG
1752	4 x 39W, T5, G5, DIM ECO
1753	4 x 39W, T5, G5, DIM EXCEL
1754	4 x 39W, T5, G5, DIM ANALOG 1-10V

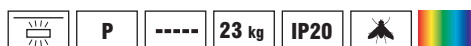
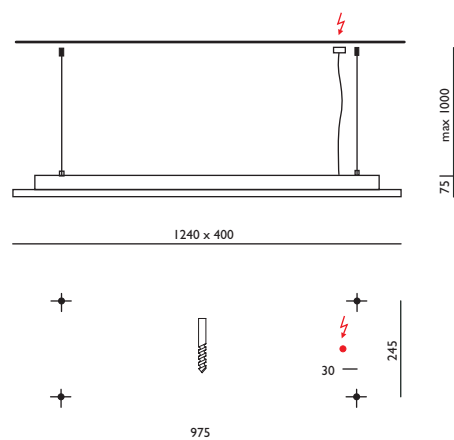



Design by Alexander Dubský



White line

Q series



Q155 CODE **4,3 kg**

- 1335 36W, TC-L, 2G11, KVG
- 1336 55W, TC-L, 2G11, EVG
- 1337 55W, TC-L, 2G11, DIM ECO
- 1338 55W, TC-L, 2G11, DIM EXCEL
- 1339 55W, TC-L, 2G11, DIM ANALOG 1-10V

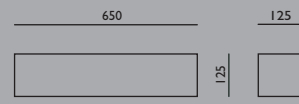

Q142 CODE **1,5 kg**

- 1340 max 60W, A45, E27
- 1341 100W, QT-DE12, 74,9 mm, R7s
- 1342 26W, TC-D, G24d-3, KVG
- 1343 26W, TC-DEL, G24q-3, EVG

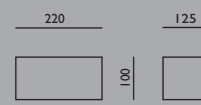

QND series

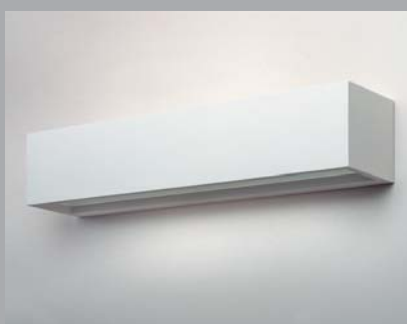

QND155 CODE **3,9 kg**

- 1345 36W, TC-L, 2G11, KVG
- 1346 55W, TC-L, 2G11, EVG
- 1347 55W, TC-L, 2G11, DIM ECO
- 1348 55W, TC-L, 2G11, DIM EXCEL
- 1349 55W, TC-L, 2G11, DIM ANALOG 1-10V

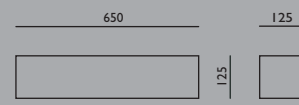

QND142 CODE **1,1 kg**

- 1350 max 60W, A45, E27
- 1351 26W, TC-D, G24d-3, KVG
- 1352 26W, TC-DEL, G24q-3, EVG

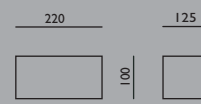

DS series



DS109 CODE **4,0 kg**

- 1160 2 x 18W, TC-L, 2G11, KVG
- 1161 2 x 18W, TC-L, 2G11, EVG
- 1162 2 x 36W, TC-F, 2G10, KVG
- 1163 2 x 36W, TC-F, 2G10, EVG

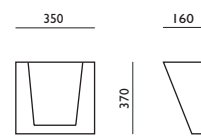

Bolt CODE **3,1 kg**

- 1133 24W, TC-L, 2G11, KVG
- 1152 24W, TC-L, 2G11, EVG

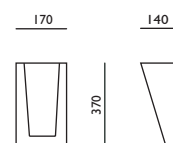



D109 CODE **4,4 kg**

- 1145 max 23W, TC-TSE, E27
- 1146 150W, QT-DE12, 114,2 mm, R7s
- 1147 75W, HIT-DE, Rx7s
- 1149 26W, TC-D, G24d-3, KVG
- 1150 26W, TC-D, G24d-3, KVG, EE
- 1151 42W, TC-DEL, Gx24q-4, EVG

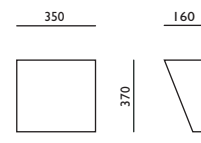

D159 CODE **2,9 kg**

- 1130 26W, TC-T, Gx24d-3, KVG
- 1131 26W, TC-TEL, Gx24q-3, EVG
- 1132 100W, QT-DE12, 74,9 mm, R7s

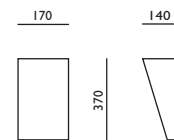

D156 CODE **4,7 kg**

- 1135 max 23W, TC-TSE, E27
- 1136 150W, QT-DE12, 114,2 mm, R7s
- 1137 75W, HIT-DE, Rx7s
- 1139 32W, TC-TEL, Gx24q-3, EVG
- 1140 32W, TC-TEL, Gx24q-3, EVG, EE

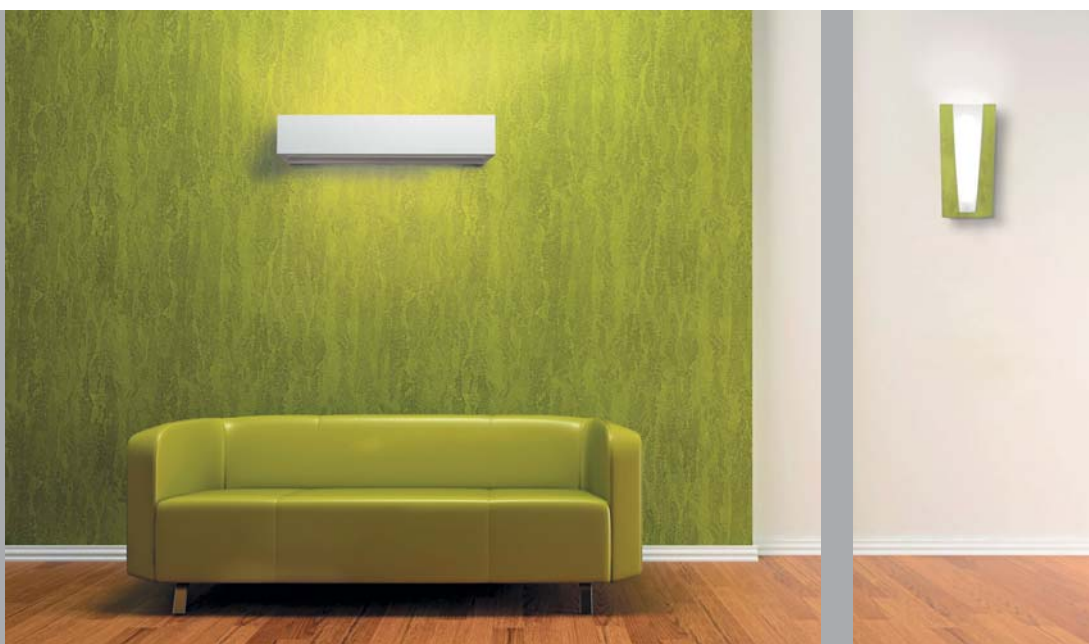
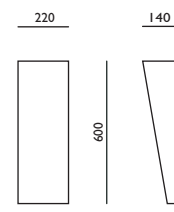

Chic series

CODE **Chic SQT 2000**

1600	4 x 58W, T8, G13, KVG
1601	4 x 58W, T8, G13, EVG
1602	4 x 35W, T5, G5, EVG, EE
1603	8 x 35W, T5, G5, EVG
1604	8 x 35W, T5, G5, DIM ECO
1605	8 x 35W, T5, G5, DIM EXCEL
1606	8 x 35W, T5, G5, DIM ANALOG 1-10V

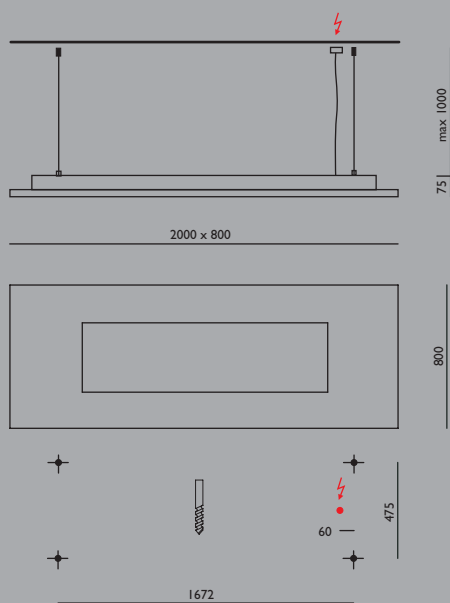

Design by Alexander Dubský





ST series

ST 123

CODE	3,8 kg
1550	2 x 18W, TC-L, 2G11, EVG
1551	4 x 18W, TC-L, 2G11, EVG

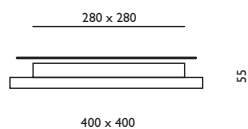

ST 126

CODE	12 kg
1541	4 x 24W, TC-L, 2G11, EVG
1542	4 x 24W, TC-L, 2G11, DIM ECO
1543	4 x 24W, TC-L, 2G11, DIM EXCEL
1545	4 x 24W, TC-L, 2G11, EVG + 4 x 8W, T5, G5, EVG
1546	4 x 24W, TC-L, 2G11, DIM ECO + 4 x 8W, T5, G5, EVG
1547	4 x 24W, TC-L, 2G11, DIM EXCEL + 4 x 8W, T5, G5, EVG

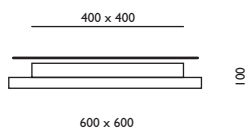

ST 127

CODE	22 kg
1525	4 x 36W, TC-L, 2G11, EVG
1526	4 x 36W, TC-L, 2G11, DIM ECO
1527	4 x 36W, TC-L, 2G11, DIM EXCEL
1538	4 x 36W, TC-L, 2G11, DIM ANALOG 1-10V
1529	4 x 36W, TC-L, 2G11, EVG + 4 x 8W, T5, G5, EVG
1530	4 x 36W, TC-L, 2G11, DIM ECO + 4 x 8W, T5, G5, EVG
1531	4 x 36W, TC-L, 2G11, DIM EXCEL + 4 x 8W, T5, G5, EVG

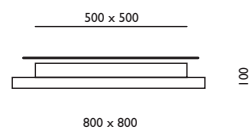

indirect lighting / nepřímé osvětlení
+ 4 x 8W, T5, G5, EVG

Czech design 1995-2000
Český design 1995-2000

Design by Alexander Dubský



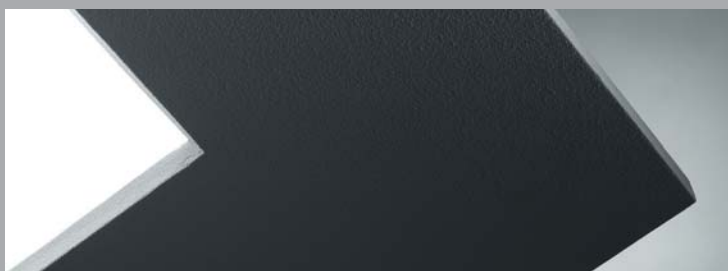

Design by Alexander Dubský



STZ series

STZ 123

CODE	4,8 kg
1552	2 x 18W, TC-L, 2G11, KVG
1553	2 x 18W, TC-L, 2G11, EVG
1554	4 x 18W, TC-L, 2G11, EVG

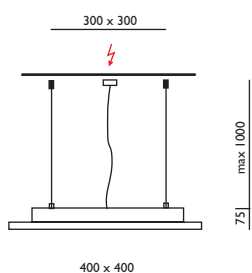

STZ 126

CODE	15 kg
1560	4 x 24W, TC-L, 2G11, KVG
1561	4 x 24W, TC-L, 2G11, EVG
1562	4 x 24W, TC-L, 2G11, DIM ECO
1563	4 x 24W, TC-L, 2G11, DIM EXCEL

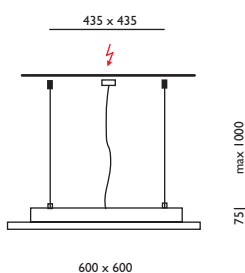

STZ 127

CODE	25 kg
1555	4 x 36W, TC-L, 2G11, KVG
1557	4 x 36W, TC-L, 2G11, EVG
1558	4 x 36W, TC-L, 2G11, DIM ECO
1559	4 x 36W, TC-L, 2G11, DIM EXCEL
1564	4 x 36W, TC-L, 2G11, DIM ANALOG 1-10V

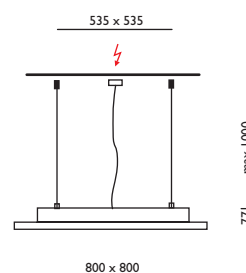

Grip series



Design by Alexander Dubský



Grip 1

CODE 4570

8W, T5, G5, EVG

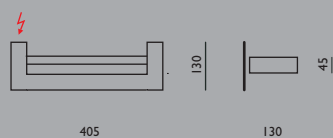

1,7 kg

Grip 2

CODE 4571

24W, T5, G5, EVG

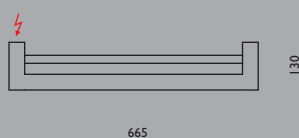

2,4 kg

Grip 3

CODE 4572

39W, T5, G5, EVG

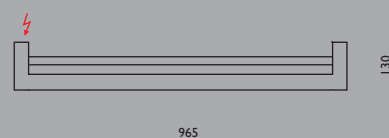

3,4 kg



Frame series



Design by Alexander Dubský

Frame S

CODE 4590 **8,2 kg**

4 x 24W, T5, G5, EVG

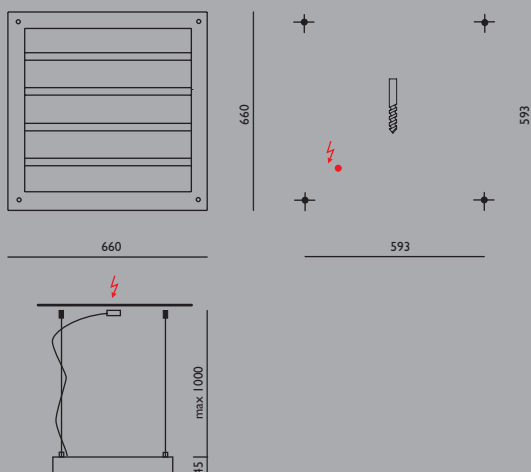

Frame 0

CODE 4580 **8,2 kg**

2 x 39W, T5, G5, EVG

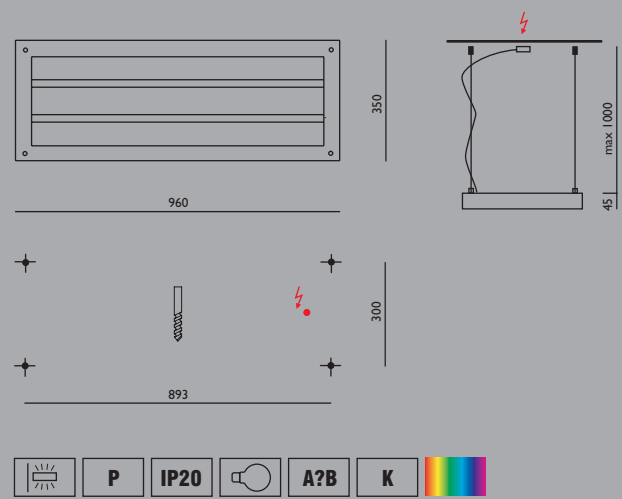



SQ122



Design by Alexander Dubský

SQ122

CODE

1500	4 x 36W, T8, G13, KVG
1501	4 x 36W, T8, G13, EVG
1502	4 x 36W, T8, G13, DIM ECO
1503	4 x 36W, T8, G13, DIM EXCEL
1504	4 x 36W, T8, G13, DIM ANALOG 1-10V

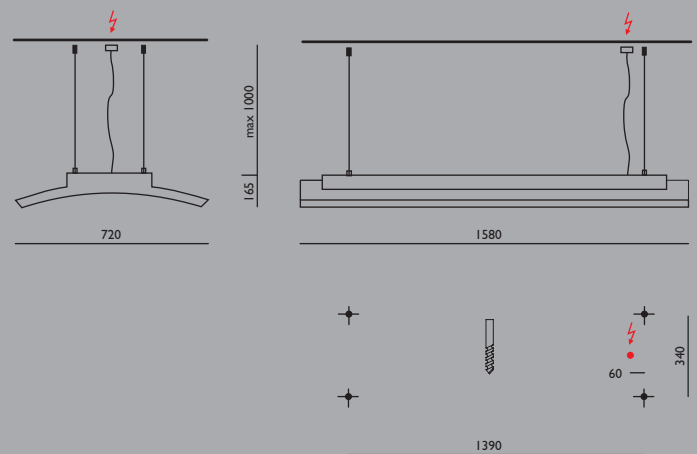

 **P**  **23 kg** **IP20** 





Filler series



Filler 1

CODE

1710 max 100W, A60, E27
+ max 50W/230V, ES 50, GU10

1711 max 23W, TC-TSE, E27
+ max 50W/230V, ES 50, GU10 

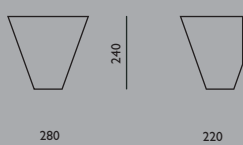

Filler 2

CODE

1718 2 x max 40W, A45, E27
+ max 50W/230V, ES 50, GU10





Design by Pavel Knappek

AKG 173

CODE

1728 max 100W, A60, E27 + max 15W, TC-TSE, E27

1729 max 23W, TC-TSE, E27 + 15W, TC-TSE, E27 

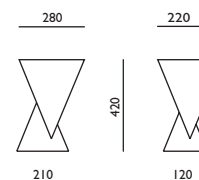

G series



GL112 CODE

3,4 kg

1190 2 x max 40W, A45, E27

1191 2 x max 15W, TC-TSE, E27 

1192 2 x 26W, TC-D, G24d-3, KVG 

1193 2 x 26W, TC-D, G24d-3, KVG, EE 

1194 2 x 26W, TC-DEL, G24q-3, EVG 

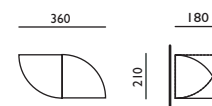

GP112 CODE

3,4 kg

1195 2 x max 40W, A45, E27

1196 2 x max 15W, TC-TSE, E27 

1197 2 x 26W, TC-D, G24d-3, KVG 

1198 2 x 26W, TC-D, G24d-3, KVG, EE 

1199 2 x 26W, TC-DEL, G24q-3, EVG 

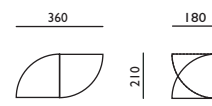

White line

A series



A100	CODE	0,9 kg
1010	max 60W, A45, E27	
1011	10-13W, TC-D, G24d-1, KVG	
1012	10-13W, TC-DEL, G24q-1, EVG	

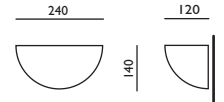

A101	CODE	1,4 kg
1020	max 60W, A45, E27	
1021	100W, QT-DE12, 74,9 mm, R7s	
1022	26W, TC-D, G24d-3, KVG	
1023	26W, TC-DEL, G24d-3, EVG	

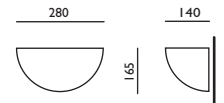

A102	CODE	2,9 kg
1030	max 100W, A60, E27	
1031	max 23W, TC-TSE, E27	
1032	150W, QT-DE12, 114,2 mm, R7s	
1033	75W, HIT-DE, Rx7s	
1035	150W, QT-DE12, 114,2 mm, R7s + 75W, HIT-DE, Rx7s	
1037	26W, TC-D, G24d-3, KVG	
1038	26W, TC-D, G24d-3, KVG, EE	
1043	2 x 26W, TC-DEL, G24q-3, EVG	
1044	2 x 26W, TC-DEL, G24q-3, EVG, EE	

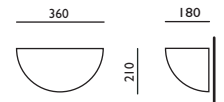

AD101	CODE	
1060	26W, TC-T, Gx24d-3, KVG	
1061	26W, TC-TEL, Gx24q-3, EVG	

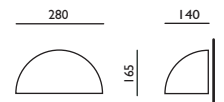

B series



B104	CODE	2,2 kg
1070	max 60W, A45, E27	
1071	26W, TC-T, Gx24d-3, KVG	
1072	26W, TC-TEL, Gx24q-3, EVG	

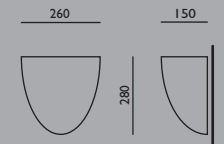

B105	CODE	4,9 kg
1075	max 100W, A60, E27	
1076	max 23W, TC-TSE, E27	
1077	150W, QT-DE12, 114,2 mm, R7s	
1078	75W, HIT-DE, Rx7s	
1080	26W, TC-D, G24d-3, KVG, EE	
1082	26W, TC-DEL, G24q-3, EVG, EE	
1083	42W, TC-TEL, Gx24q-4, EVG	

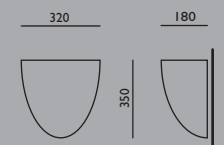

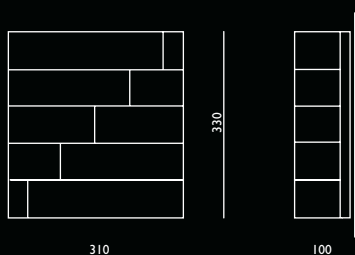

Stairs

CODE 4610

2 x 60W, A45, (2 x 15W, TC-TSE), E27



Design by Miroslav Oliva

C series



C107

CODE

4,2 kg

- 1110 2 x max 100W, A60, E27
- 1111 2 x max 23W, TC-TSE, E27
- 1112 36W, TC-L, 2G11, KVG
- 1113 36W, TC-L, 2G11, KVG, EE
- 1114 55W, TC-L, 2G11, EVG
- 1115 55W, TC-L, 2G11, EVG, EE

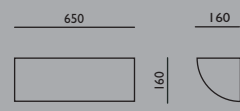

C106

CODE

2,0 kg

- 1090 max 100W, A60, E27
- 1091 max 23W, TC-TSE, E27
- 1092 150W, QT-DE12, 114,2mm, R7s
- 1093 75W, HIT-DE, Rx7s
- 1096 26W, TC-D, G24d-3, KVG, EE
- 1098 26W, TC-DEL, G24q-3, EVG, EE
- 1099 2 x 26W, TC-D, G24d-3, KVG
- 1100 2 x 26W, TC-D, G24d-3, KVG, EE

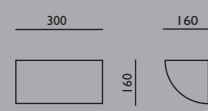

CD series



CD107

CODE

4,1 kg

- 1125 36W, TC-L, 2G11, KVG
- 1126 55W, TC-L, 2G11, EVG

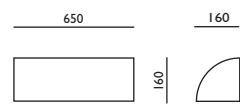

CD106

CODE

2,0 kg

- 1120 max 60W, A60, E27
- 1121 max 23W, TC-TSE, E27

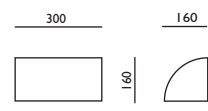

E series

ECO-DESIGN



E110

CODE

3,6 kg

- 1170 max 100W, A60, E27
- 1171 max 23W, TC-TSE, E27
- 1172 26W, TC-TEL, G24q-3, EVG, EE
- 1173 2 x 26W, TC-D, G24d-3
+ TC-T, Gx24d-3, KVG

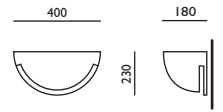

E125

CODE

1,9 kg

- 1175 max 100W, A60, E27
- 1176 26W, TC-D, G24d-3, KVG
- 1177 max 23W, TC-TSE, E27, EVG

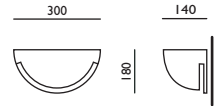

I series



I114

CODE

2,9 kg

- 1265 max 100W, A60, E27
- 1266 max 23W, TC-TSE, E27
- 1267 150W, QT-DE12, 114,2 mm, R7s
- 1268 75W, HIT-DE, Rx7s
- 1270 150W, QT-DE12, 114,2 mm, R7s
+ 75W, HIT-DE, Rx7s
- 1272 26W, TC-D, G24d-3, KVG
- 1273 26W, TC-D, G24d-3, KVG, EE
- 1276 2 x 26W, TC-D, G24d-3, KVG
- 1277 2 x 26W, TC-D, G24d-3, KVG, EE

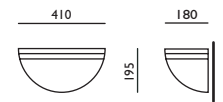

I157

CODE

1,1 kg

- 1285 max 60W, A60, E27
- 1286 100W, QT-DE12, 74,9 mm, R7s
- 1287 26W, TC-D, G24d-3, KVG
- 1288 26W, TC-DEL, G24q-3, EVG

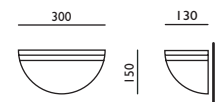

M145



Design by Jiří Pták

M145

CODE

1,9 kg

- 1305 2 x max 100W, A60, E27
- 1306 2 x max 23W, TC-TSE, E27
- 1305/44 2 x max 100W, A60, E27
- 1306/44 2 x max 23W, TC-TSE, E27

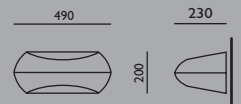

White line

N series



N143

CODE

2,0 kg

1310 max 100W, A60, E27
1311 26W, TC-D, G24d-3, KVG 
1312 26W, TC-DEL, G24q-3, EVG 

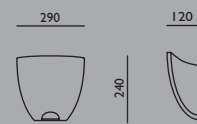

NS143

CODE

1,9 kg

1315 max 100W, A60, E27
1316 26W, TC-D, G24d-3, KVG 
1317 26W, TC-DEL, G24q-3, EVG 

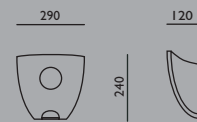

Design by Alexander Dubský



K series



K147

CODE

2,2 kg

1295 max 100W, A60, E27
1296 max 23W, TC-TSE, E27 
1297 26W, TC-D, G24d-3, KVG 
1298 26W, TC-DEL, G24q-3, EVG 

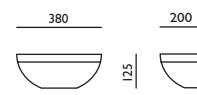

K158

CODE

1,3 kg

1300 max 60W, A45, E27
1301 max 15W, TC-TSE, E27 
1302 26W, TC-D, G24d-3, KVG 
1303 26W, TC-DEL, G24q-3, EVG 

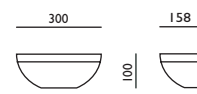

Design by Jiří Pták









Design by Alexander Dubský



U128

CODE

5,4 kg

- 1380 2 x max 100W, A60, E27
- 1381 2 x 26W, TC-D, G24d-3
+ TC-T, Gx24d-3, KVG 
- 1382 2 x 26W, TC-DEL, G24q-3
+ TC-TEL, Gx24q-3, EVG, EE 
- 1383 2 x 32W, TC-TEL, Gx24q-3, EVG 
- 1384 2 x 32W, TC-TEL, Gx24q-3, EVG, EE 

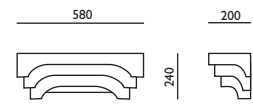

T144

CODE

2,4 kg

- 1370 max 100W, A60, E27
- 1371 max 23W, TC-TSE, E27 
- 1372 26W, TC-D, G24d-3, KVG 

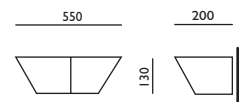

R series



RA102 CODE **2,1 kg**
 1355 max 60W, A45, E27
 1356 max 15W, TC-TSE, E27 

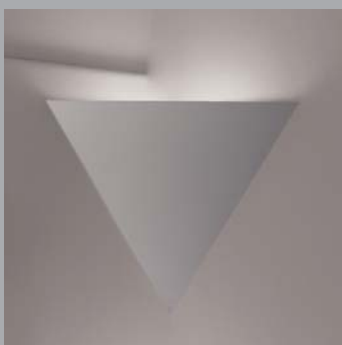
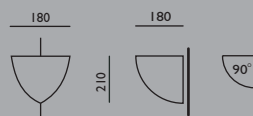

RT133 CODE **3,0 kg**
 1365 max 60W, A45, E27
 1366 max 15W, TC-TSE, E27 

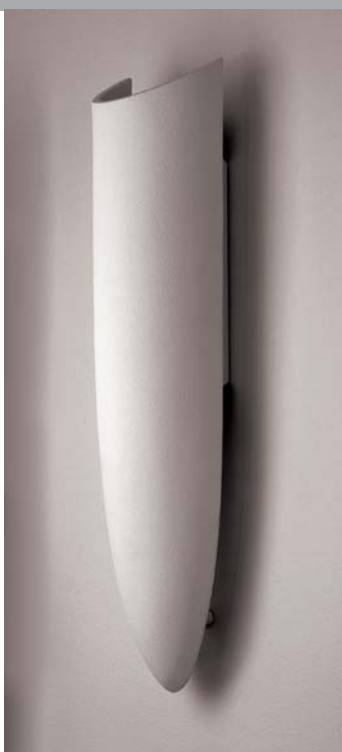
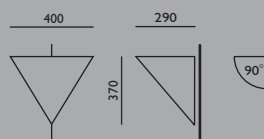

Z163 CODE **2,7 kg**
 1418 2 x max 100W, A60, E27

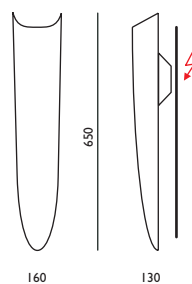



S1 CODE

- 1811 max 50W/12V, GU5,3
- 1812 max 50W/230V, ES 50, GU10
- 1813 Power LED 3W, GU10/230V

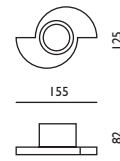

S2 CODE

- 1821 max 50W/12V, GU5,3
- 1822 max 50W/230V, ES 50, GU10
- 1823 Power LED 3W/230V, GU10

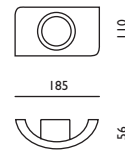

S6 CODE

- 1861 max 50W/12V, GU5,3
- 1862 max 50W/230V, ES 50, GU10
- 1863 Power LED 3W/230V, GU10

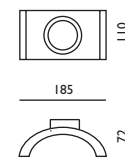

S9 CODE

- 1890 max 50W/12V, GU5,3
- 1891 max 50W/230V, ESD-50, GZ10
- 1892 Power LED 3W/230V, GU10

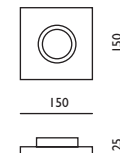

S10 CODE

- 1910 max 50W/12V, GU5,3
- 1911 max 50W/230V, ESD-50, GZ10
- 1912 Power LED 3W/230V, GU10

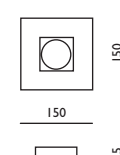

S11 CODE

- 1920 max 50W/12V, GU5,3
- 1921 max 50W/230V, ESD-50, GZ10
- 1922 Power LED 3W/230V, GU10

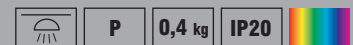
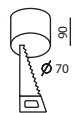

SA / SY serie



Czech Product of the Year 2000
Design by Alexander Dubský

SA148 CODE **1,8 kg**
1520 max 60W, A60, E27
1522 13W, TC-DEL, G24q-1, EVG

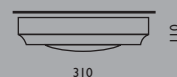

SA149 CODE **4,4 kg**
1517 2 x max 60W, A60, E27
1519 2 x 26W, TC-DEL, G24q-3, EVG



SY135 CODE **10 kg**
1505 3 x max 60W, A60, E27
1508 2 x 36W, TC-F, 2G10, EVG
1509 2 x 36W, TC-F, 2G10, DIM ECO
1510 2 x 36W, TC-F, 2G10, DIM EXCEL



SY136 CODE **4,4 kg**
1511 2 x max 60W, A60, E27
1513 2 x 26W, TC-DEL, G24q-3, EVG

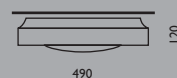

SY137 CODE **1,8 kg**
1514 max 60W, A60, E27
1516 13W, TC-DEL, G24q-1, EVG



SYP136

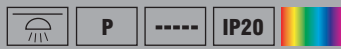

SYP136 CODE **6,3 kg**
 1590 2 x max 60W, A45, E27
 1592 2 x 26W, TC-DEL, G24q-3, EVG

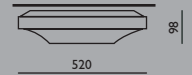

SP74



SP74 CODE **6,8 kg**
 1654 2 x 36W, TC-F, 2G10, EVG
 1655 2 x 36W, TC-F, 2G10, DIM ECO
 1656 2 x 36W, TC-F, 2G10, DIM EXCEL

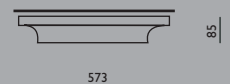

SYJ137



Design by Jiří Pták



SYJ137 CODE **3,4 kg**
 1585 max 60W, A60, E27
 1587 13W, TC-DEL, G24q-1, EVG

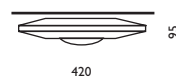

Flute series



Flute D1 1,0 kg

CODE 4201 max 40W, G9

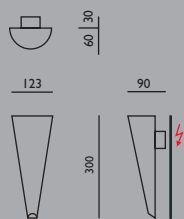

Flute D2 1,6 kg

CODE 4202 2 x max 40W, G9

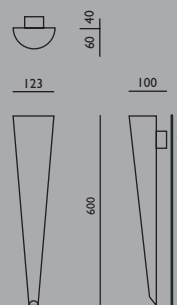

Flute D3 2,6 kg

CODE 4203 2 x max 40W, G9

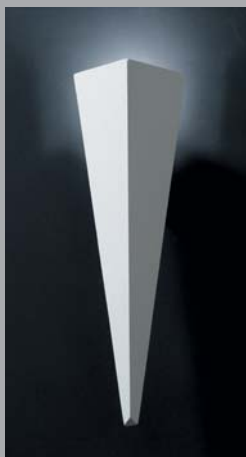
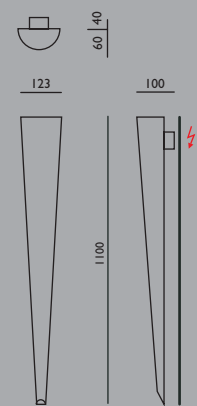

Flute V1 1,0 kg

CODE 4211 max 40W, G9

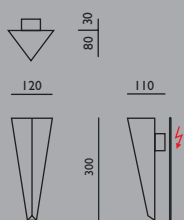

Flute V2 1,6 kg

CODE 4212 2 x max 40W, G9

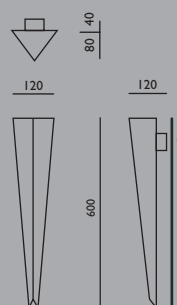

Flute V3 2,6 kg

CODE 4213 2 x max 40W, G9

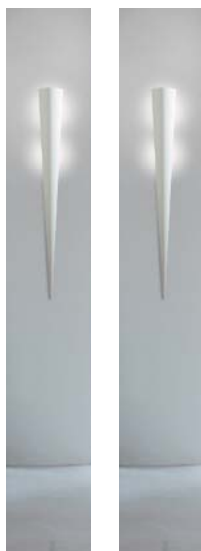
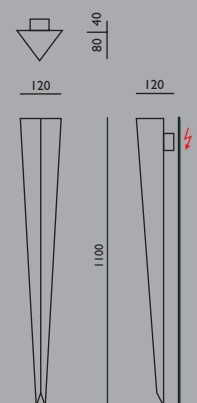



Flute U1 1,3 kg

CODE 4221 max 40W, G9

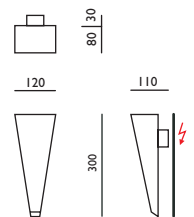

Flute U2 2,2 kg

CODE 4222 2 x max 40W, G9

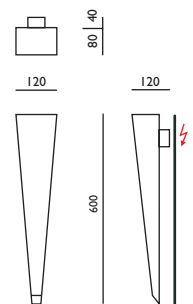

Flute U3 3,8 kg

CODE 4223 2 x max 40W, G9

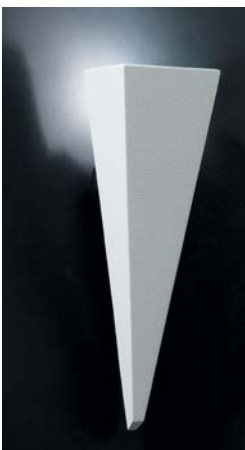
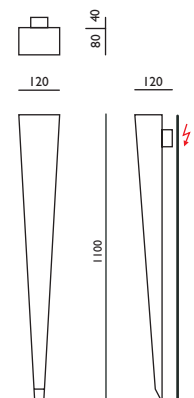

Oboe series



Oboe D1 1,6 kg

CODE 4301 2 x max 25W, G9

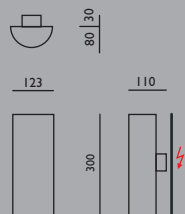

Oboe D2 2,9 kg

CODE 4302 14W, T5, G5, EVG

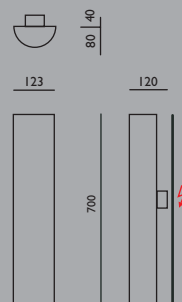

Oboe D3 4,9 kg

CODE 4303 21W, T5, G5, EVG

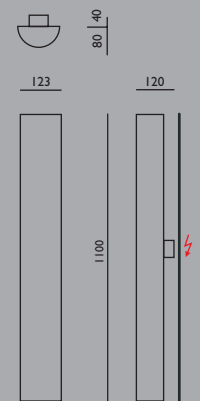

Oboe V1 1,5 kg

CODE 4311 2 x max 25W, G9

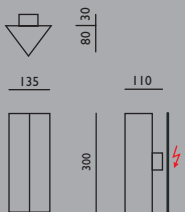

Oboe V2 2,7 kg

CODE 4312 14W, T5, G5, EVG



Oboe V3 4,6 kg

CODE 4313 21W, T5, G5, EVG

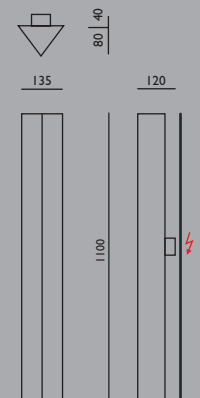



Oboe U1 2,2 kg

Oboe U2 4,3 kg

Oboe U3 7,3 kg

CODE 4321 2 x max 25W, G9

CODE 4322 2 x 14W, T5, G5, EVG

CODE 4323 2 x 21W, T5, G5, EVG

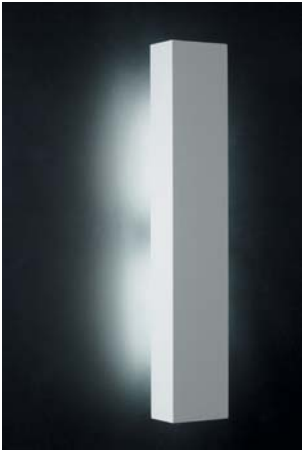
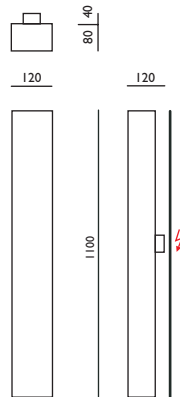
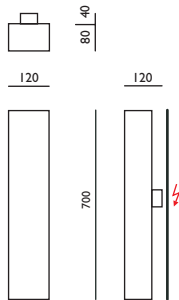
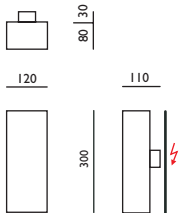

Leader series



Leader S

CODE 4101 5W, TC-SL, 2G7, EVG
 CODE 4102 2 x 5W, TC-SL, 2G7, EVG

Installation box not included / Montážní box není součástí

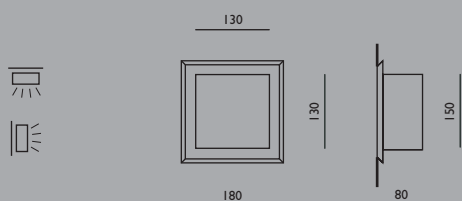

Leader R

CODE 4111 5W, TC-SL, 2G7, EVG
 CODE 4112 2 x 5W, TC-SL, 2G7, EVG

Installation box not included / Montážní box není součástí

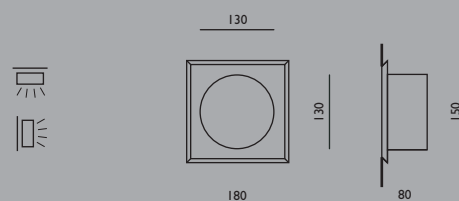

Installation box / Montážní box

CODE 4115 Installation box for plasterboard / Montážní box pro sádkrokarton
 CODE 4116 Installation box for other constructions / Montážní box pro ostatní





Installation / Montáž



Installation hole / Montážní otvor 190 x 190 x 93 mm

Silverline

Silverline



Bologna series 71 Page

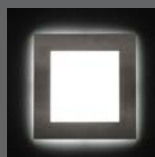

Venezia series 72 Page



Milano series 70



Verona series 74



Milano S 70



Venezia LED series 73



Roma series 68



Verona LED series 75



Torino series 66



LED Info 76

EN / Cool perfection and elegance does not have to end after the first encounter. Silverline will prove its advantages to you in daily trials.

CZ / Chladná dokonalost a elegance nemusí v tomto případě skončit jen jedním setkáním. O svých přednostech Vás denně bude při nejnáročnějších zkouškách přesvědčovat Silverline.

DE / Die kühle Perfektion und Eleganz müssen in diesem Fall nicht durch ein einziges Treffen beendet werden. Über ihre Vorzüge wird Sie Silverline bei den anspruchsvollsten Prüfungen täglich überzeugen.

FR / Dans ce cas, la perfection froide et l'élégance ne se rencontrent pas uniquement pour une seule fois. Silverline vous persuadera chaque jour de ses qualités dans les conditions d'utilisation sévères.

RUS / Холодное совершенство и изящество в данном случае не ограничивается единственной встречей. Silverline вас будет убеждать о своих преимуществах во время самых требовательных испытаний каждый день.



Stainless steel. Safety glass. Duplex opal glass. Perspex.

Nerezová ocel. Sklo Stratobel. Duplex opál. Perspex.

Edelstahl. Glas Stratobel. Duplex Opal. Perspex.

Inox. Verre laiteux Stratobel. Brûlure Duplex. Perspex.

Нержавеющая сталь. Стратобел. Дуплекс опал. Плексиглас.

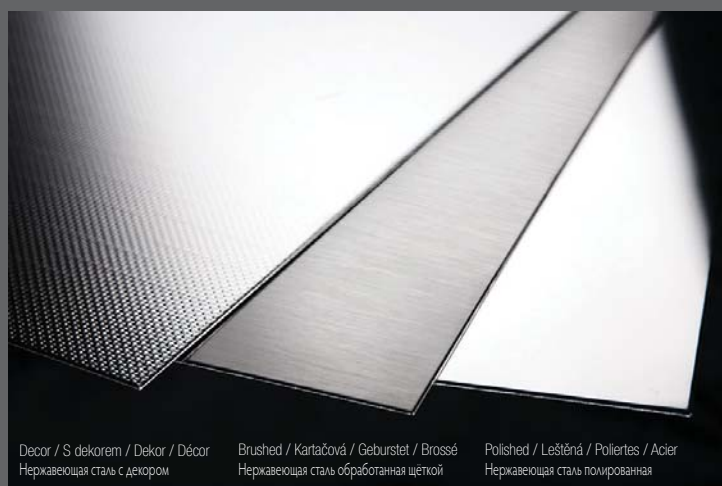

Decor / S dekorem / Dekor / Décor
Нержавеющая сталь с декором

Brushed / Kartačová / Geburset / Brossé
Нержавеющая сталь обработанная щеткой

Polished / Leštěná / Poliertes / Acier
Нержавеющая сталь полированная

Torino series

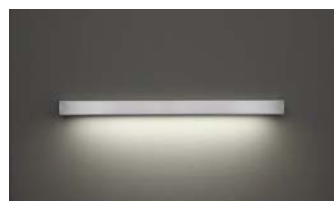

Design by Alexander Dubský



Torino 1

Torino 2

Torino 3

	CODE	8W, T2, W 4,3x8,5d, EVG	CODE	11W, T2, W 4,3x8,5d, EVG	CODE	13W, T2, W 4,3x8,5d, EVG
	4615	1A	4618	2A	4621	3A
	4616	1B	4619	2B	4622	3B
	4617	1E	4620	2E	4623	3E

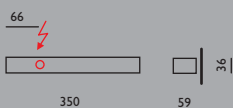

1,1 kg

1,4 kg

1,8 kg

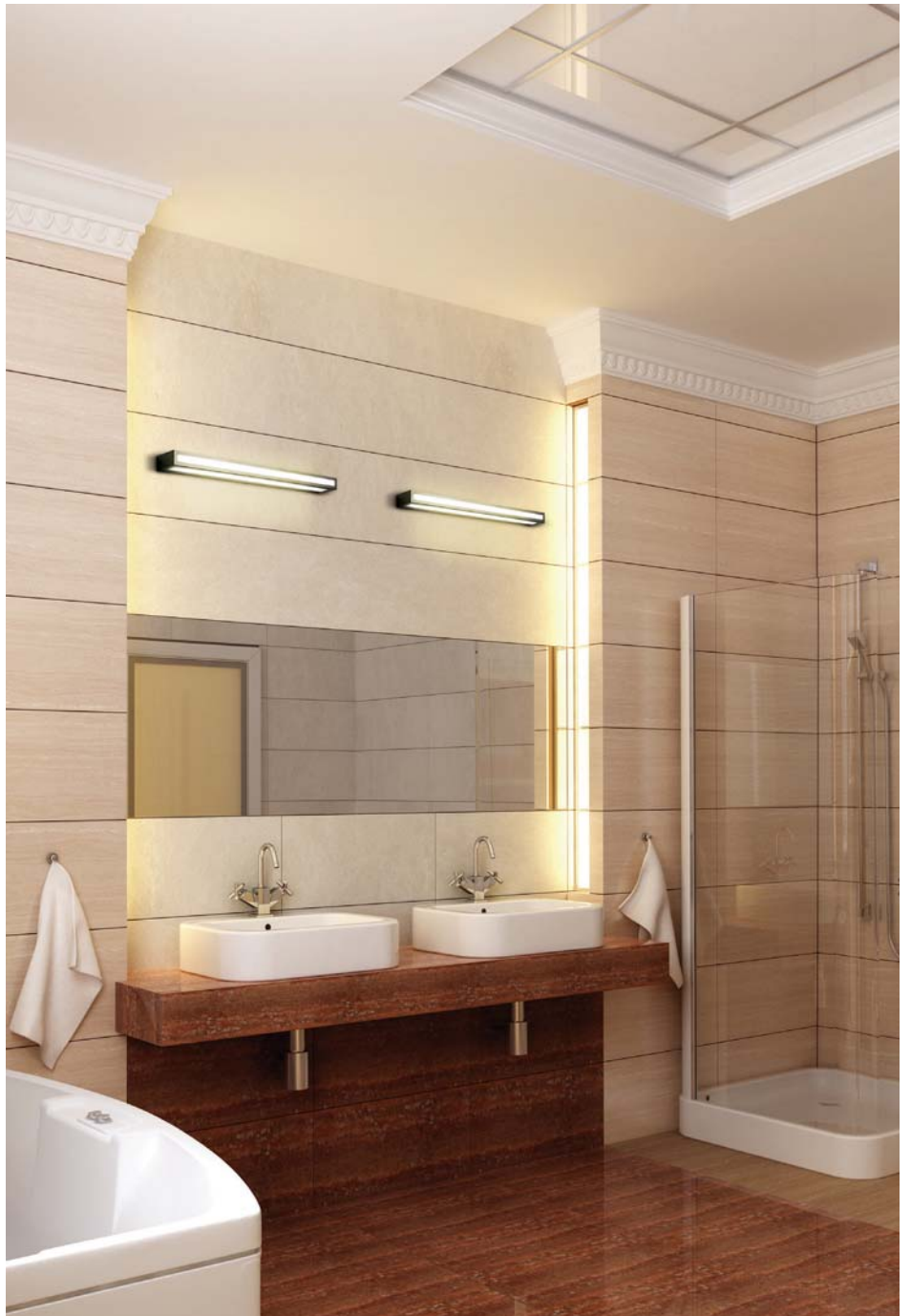

Roma serie s

Roma 1

1,9 kg

CODE

	4010	1A	24W, T5, G5, EVG
	4011	1B	24W, T5, G5, EVG
	4012	1C	24W, T5, G5, EVG
	4014	1E	24W, T5, G5, EVG

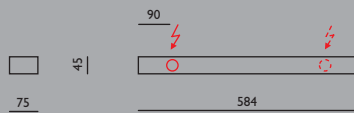

Roma 2

2,5 kg

CODE

	4020	2A	39W, T5, G5, EVG
	4021	2B	39W, T5, G5, EVG
	4022	2C	39W, T5, G5, EVG
	4024	2E	39W, T5, G5, EVG

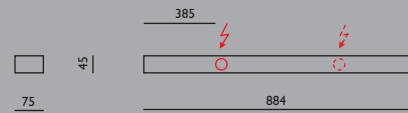

Roma 3

3,8 kg

CODE

	4030	3A	54W, T5, G5, EVG
	4031	3B	54W, T5, G5, EVG
	4032	3C	54W, T5, G5, EVG
	4034	3E	54W, T5, G5, EVG

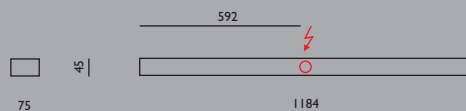

Roma 4

5,1 kg

CODE

	4040	4A	80W, T5, G5, EVG
	4041	4B	80W, T5, G5, EVG
	4042	4C	80W, T5, G5, EVG
	4044	4E	80W, T5, G5, EVG

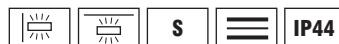
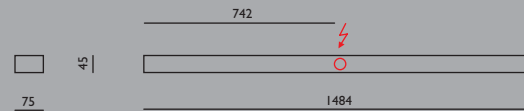

Design by Alexander Dubský





Roma mini

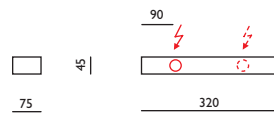

CODE

		4007	A	8W, T5, G5, EVG
		4008	B	8W, T5, G5, EVG
		4009	E	8W, T5, G5, EVG



Roma LOGO



Milano series



Milano 1

CODE	9,1 kg
4050	4 x 24W, T5, G5, EVG
4051	8 x 24W, T5, G5, EVG
4052	8 x 24W, T5, G5, DIM ECO
4053	8 x 24W, T5, G5, DIM EXCEL
4054	8 x 24W, T5, G5, DIM ANALOG 1-10V

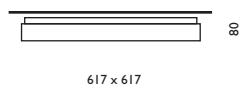

Milano 2

CODE	4,2 kg
4055	2 x 18W, TC-L, 2G11, EVG
4056	4 x 18W, TC-L, 2G11, EVG

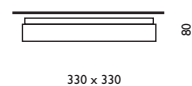

Milano S

CODE	9,1 kg
4060	4 x 24W, T5, G5, EVG

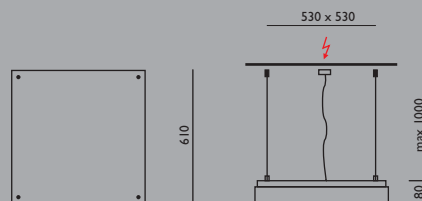



Bologna series

Bologna S



CODE **2,8 kg**
 1623 2 x 18W, TC-L, 2G11, EVG

CODE **6,4 kg**
 1625 4 x 24W, T5, G5, EVG
 1626 4 x 24W, T5, G5, DIM ECO
 1627 4 x 24W, T5, G5, DIM EXCEL
 1632 4 x 24W, T5, G5, DIM ANALOG 1-10V

CODE **12 kg**
 1628 4 x 39W, T5, G5, EVG
 1629 4 x 39W, T5, G5, DIM ECO
 1630 4 x 39W, T5, G5, DIM EXCEL
 1631 4 x 39W, T5, G5, DIM ANALOG 1-10V

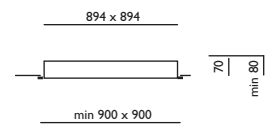
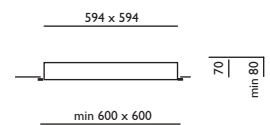
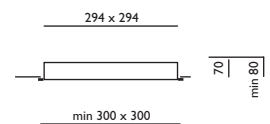

Bologna B



CODE **2,8 kg**
 1659 2 x 18W, TC-L, 2G11, EVG

CODE **6,4 kg**
 1661 4 x 24W, T5, G5, EVG
 1662 4 x 24W, T5, G5, DIM ECO
 1663 4 x 24W, T5, G5, DIM EXCEL
 1670 4 x 24W, T5, G5, DIM ANALOG 1-10V

CODE **12 kg**
 1664 4 x 39W, T5, G5, EVG
 1665 4 x 39W, T5, G5, DIM ECO
 1666 4 x 39W, T5, G5, DIM EXCEL
 1671 4 x 39W, T5, G5, DIM ANALOG 1-10V

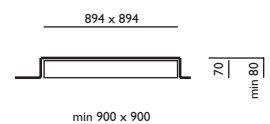
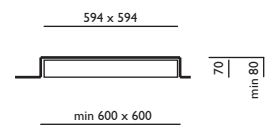
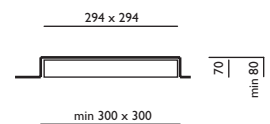

Venezia series

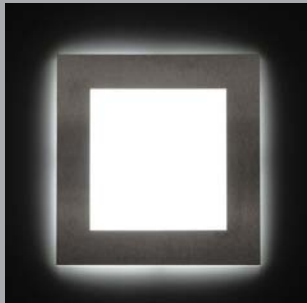

Venezia 18

CODE 1221.01 1 x 18W, TC-F, 2G10, EVG

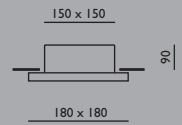

Venezia 30

CODE 1222.01 2 x 24W, TC-F, 2G10, EVG

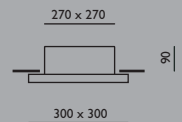

Venezia 50

CODE 1229.01 4 x 36W, TC-L, 2G11, EVG

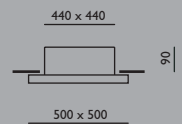

Venezia UP series



Venezia UP 20

CODE 1321.01 1 x 24W, TC-F, 2G10, EVG

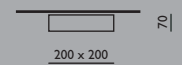

Venezia UP 35

CODE 1322.01 2 x 36W, TC-F, 2G10, EVG

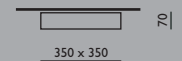

Venezia UP 50

CODE 1329.01 4 x 36W, TC-L, 2G11, EVG

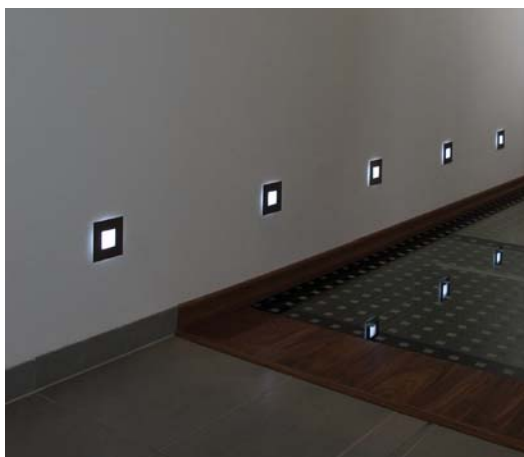
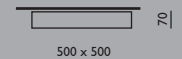



Venezia LED series

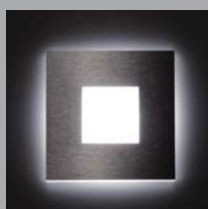

Venezia LED 8

CODE 1223.01 LED 0,7W/12V

Box not included.
Elektromontážní krabice není součástí svítidla.

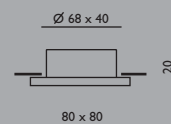

Venezia LED 15

CODE 1224.01 LED 1,5W/12V

Stainless steel box included.
Box z nerezové oceli součástí svítidla.

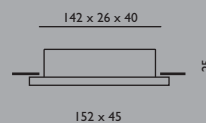

Verona series



Verona 20

CODE 1225.01 1 x 18W, TC-F, 2G10, EVG

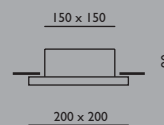

Verona 34

CODE 1226.01 2 x 24W, TC-F, 2G10, EVG

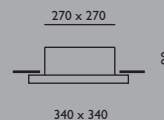

Verona 54

CODE 1230.01 4 x 36W, TC-L, 2G11, EVG

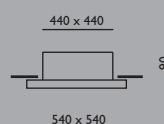

Verona UP series



Verona UP 20

CODE 1325.01 1 x 24W, TC-F, 2G10, EVG



Verona UP 35

CODE 1326.01 2 x 36W, TC-F, 2G10, EVG

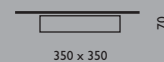

Verona UP 50

CODE 1330.01 4x36W, TC-L, 2G11, EVG

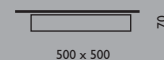



Verona LED series

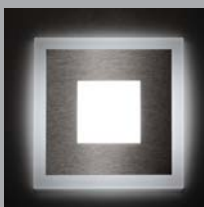

Verona LED 9

CODE 1227.01 LED 0,7W/12V

Stainless steel box included.
Box z nerezové oceli součástí svítidla.

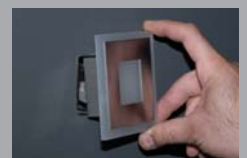
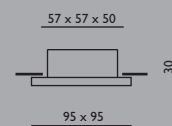

Verona LED 16

CODE 1228.01 LED 1,5W/12V

Stainless steel box included.
Box z nerezové oceli součástí svítidla.

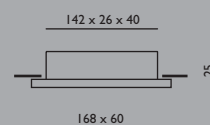

LED info

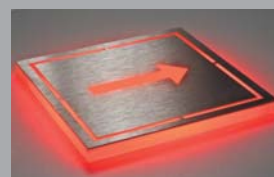
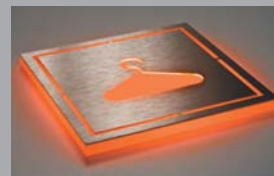
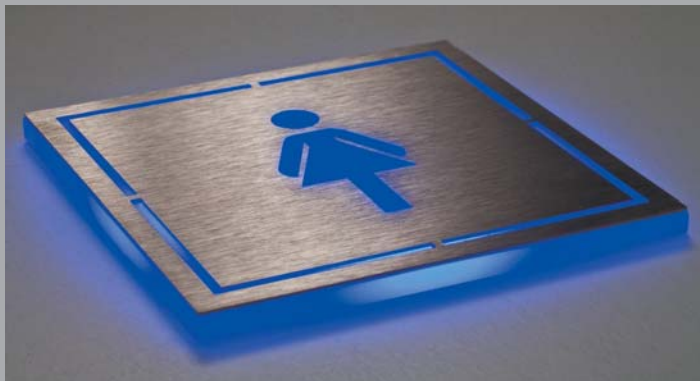

LED info

CODE 1420.01* LED 1W/12V

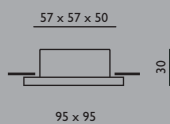

Colours / Barvy

- *W warm white / teplá bílá
- *WW cold white / studená bílá
- *R red / červená
- *G green / zelená
- *B blue / modrá
- *Y yellow / žlutá

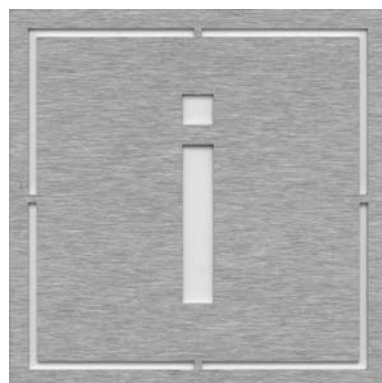
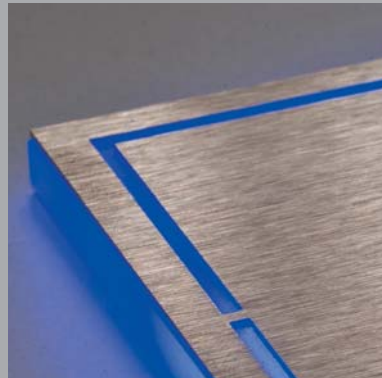

Custom design / Individuální návrh





LED Accessories / Příslušenství pro LED / Zubehör für LED / Accessoires pour LED / Аксессуары для светодиодов

CODE T1204K
12V DC, 0,42A, 5W



58 x 24 mm

CODE T1215K
12V DC, 1,25A, 15W



140 x 25,5 x 26 mm

CODE T1230K
12V DC, 2,5A, 30W



200 x 25,5 x 26 mm

CODE T1260K
12V DC, 5A, 60W



180 x 68 x 53 mm

CODE T12100K
12V DC, 12A, 100W



235 x 132 x 63 mm

Longline

Longline



AR308

82



DR508

82



Lambda

80

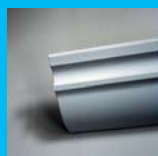

BR408

82



DRD508

82



JR333

81



CR108

82



Eta

80



QR608

82



CRT108

82



Kappa

80



PR208

82

NEW DESIGN



PikoLED

83

EN / They embrace the room into luminous line of limitless possibilities. The atmosphere is in your hands and the choice of indirect lighting is only up to you. Light up, light down, light both ways. If you want to slow down and rest in peace of gentle light all you need is a single touch of switch.

CZ / Obejmou místnost do svítící linie nekonečných možností. Atmosféra je ve Vašich rukou a záleží jen na Vás, jak s tématem nepřímého osvětlení naložíte. Svítit nahoru, dolů, nebo oběma směry. Chcete-li ubrat tempo a posadit se v klidu jemného osvětlení, je to možné pouhým stiskem tlačítka.

DE / Es umarmt das Zimmer in einer Leuchtlinie unbeschränkter Möglichkeiten. Die Stimmung liegt in Ihren Händen und es hängt nur von Ihnen ab, wie sie mit dem Thema einer indirekten Beleuchtung umgehen werden. Nach oben, nach unten oder in beide Richtungen zu leuchten. Falls Sie das Tempo reduzieren wollen und sich in Ruhe einer sanften Beleuchtung hinsetzen wollen, ist es per Knopfdruck möglich.

FR / Ils maintiennent la pièce dans une ligne lumineuse de possibilités infinies. L'ambiance est entre vos mains et c'est entièrement à vous de traiter le luminaire indirect. Eclairer le haut, le bas, les deux directions. Si vous souhaitez ralentir le rythme et profiter d'un éclairage subtil, c'est possible d'une simple pression de l'interrupteur.

RU / Охватят помещение светящейся линией безграничных возможностей. Атмосфера в Ваших руках, и зависит только от Вас, как распорядитесь непрямым освещением. Светить наверх, вниз или в обоих направлениях. Если же желаете замедлить темп и посидеть в затишье нежного освещения, просто нажмите на кнопку.



Ecolit. Natural hardened plaster. Sandblasted glass. Perspex.

Ekolit - speciální sádra. Pískované sklo. Perspex.

Ecolit. Natürlicher Hartgips. Gesandstrahlit Glas. Perspex.

Ecolith. Le plâtre durci à la base naturelle. Verre sablé. Perspex.

Эколит. Естественно упрочненный гипс. Пескоструйное стекло. Плексиглас.



Kappa



CODE 3024
 CODE 3100 

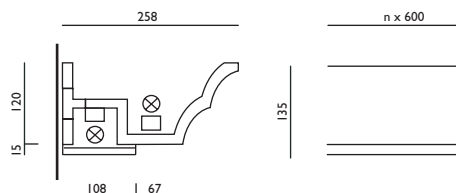

4,3 kg/1pc

Lambda



CODE 3022
 CODE 3100 

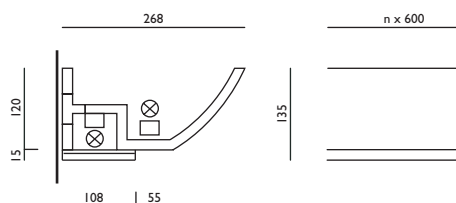

4,3 kg/1pc

Eta



CODE 3023
 CODE 3100 

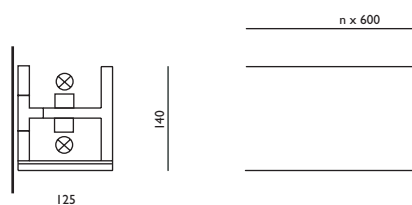

3,2 kg/1pc





JR333

Ceiling cornice / Stropní římsa / Deckengesims / Moulure du plafond / Потолочный карниз



CODE 3011

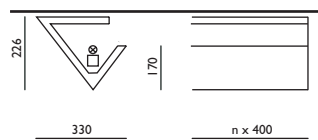

4,3 kg/1pc



Longline

AR308



CODE 3001

CODE 3100

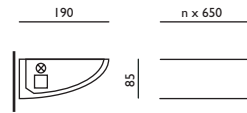

2,0 kg/1pc

BR408



CODE 3002

CODE 3100

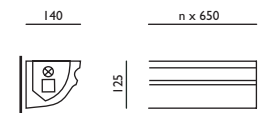

2,2 kg/1pc

A?B

IP44

CR108



CODE 3003

CODE 3100

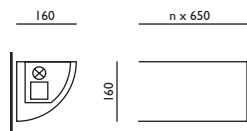

2,5 kg/1pc

A?B

IP44

CRT108



CODE 3005

CODE 3100

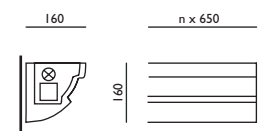

2,3 kg/1pc

A?B

IP44

PR208



CODE 3006

CODE 3100

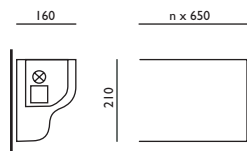

4,0 kg/1pc

A?B

IP65/IP44

QR608



CODE 3008

CODE 3100

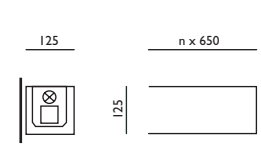

2,7 kg/1pc

A?B

IP44

DR508



CODE 3009

CODE 3100

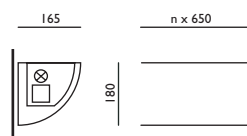

2,7 kg/1pc

A?B

IP65/IP44

DRD508



CODE 3010

CODE 3100

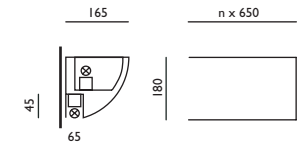

2,7 kg/1pc

A?B

IP44



CODE 3030
CODE 3100

Plaster profile / Sádrový profil

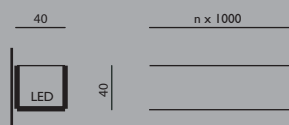

CODE 3031
CODE 3032

LED flex / Svítící kabel

LED strip / LED pásek



P

A?B

IP44



A?B

CODE 3033

RGB Controller / RGB řídicí jednotka

CODE 3034

Source / Spínaný zdroj

CODE 3035

Remote Control / Dálkový ovladač



Electric equipment and accessories / Elektrovýzbroje a příslušenství Elektronisches Vorschaltgerät und Zubehör / L'équipement électrique et Accessoires / Электрооборудование и аксессуары

Type A+B / Typ A+B

CODE	
3120	2 x 24W, T5, G5, EVG
3121	DIM ECO
3122	DIM EXCEL
3123	DIM ANALOG 1-10V

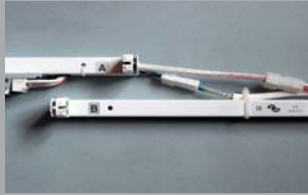

3130	2 x 39W, T5, G5, EVG
3131	DIM ECO
3132	DIM EXCEL
3133	DIM ANALOG 1-10V

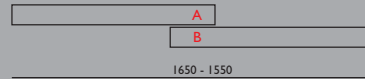

3140	2 x 54W, T5, G5, EVG
3141	DIM ECO
3142	DIM EXCEL
3143	DIM ANALOG 1-10V

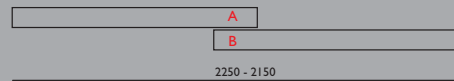

3150	2 x 49W, T5, G5, EVG
3151	DIM ECO
3152	DIM EXCEL
3153	DIM ANALOG 1-10V

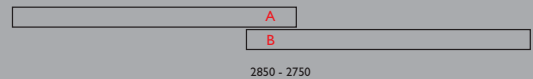

Type C / Typ C

CODE	
3160	1 x 24W, EVG
3161	DIM ECO
3162	DIM EXCEL
3163	DIM ANALOG 1-10V



3170	1 x 39W, EVG
3171	DIM ECO
3172	DIM EXCEL
3173	DIM ANALOG 1-10V

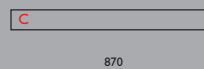

3180	1 x 54W, EVG
3181	DIM ECO
3182	DIM EXCEL
3183	DIM ANALOG 1-10V

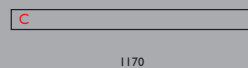

3190	1 x 49W, EVG
3191	DIM ECO
3192	DIM EXCEL
3193	DIM ANALOG 1-10V

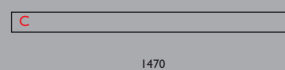

CODE 3200

Connecting part EVG / Přívodní díl EVG
Zuleitungsteil EVG / Compartiment d'alimentation EVG / Подводящая часть EVG



IP20 **EVG** **DIM** **EE**

CODE 3201

Connecting part DIM / Přívodní díl DIM
Zuleitungsteil DIM / Compartiment d'alimentation DIM / Подводящая часть DIM



CODE 3202

Extending corner part EVG / Rohový prodlužovací díl EVG
Verlängerungseckteil EVG / Compartiment rallonge de coin EVG / Угловая часть продления EVG



CODE 3203

Extending corner part DIM / Rohový prodlužovací díl DIM
Verlängerungseckteil DIM / Compartiment rallonge de coin DIM / Угловая часть продления DIM



CODE 3204

Extending corner part T5 / Rohový prodlužovací díl T5
Verlängerungseckteil T5 / Compartiment rallonge de coin T5 / Угловая часть продления T5



Electric equipment variations / Varianty skladby elektrovýzbroji

Varianten der Vorschaltgerätekombi / Variantes de la composition de l'équipement / Варианты состава электрооборудования

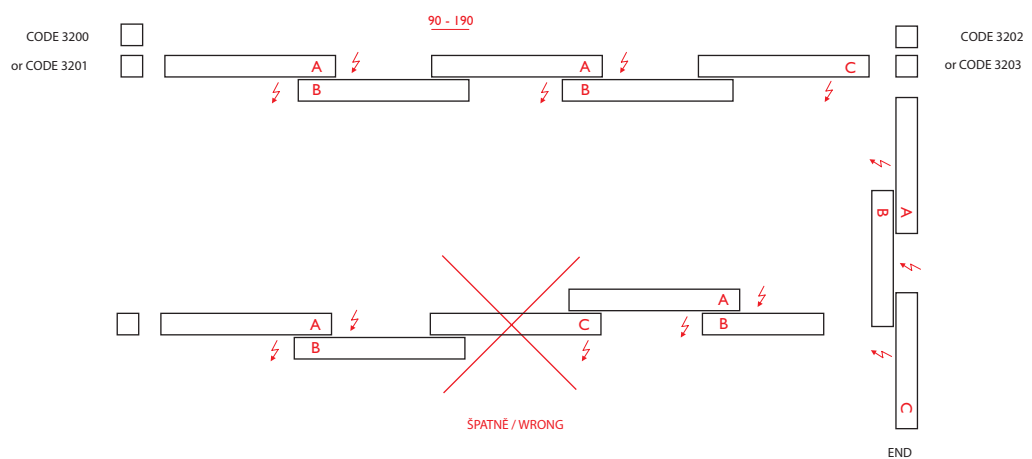
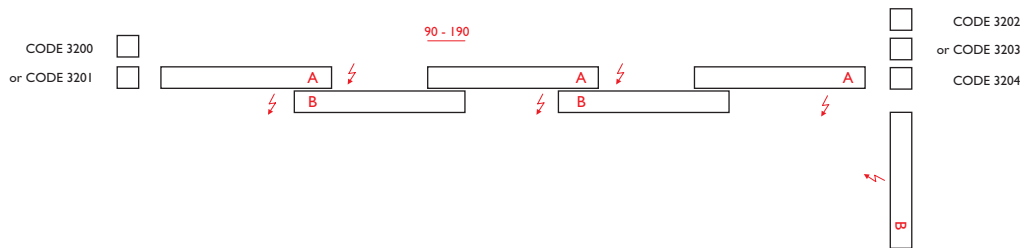
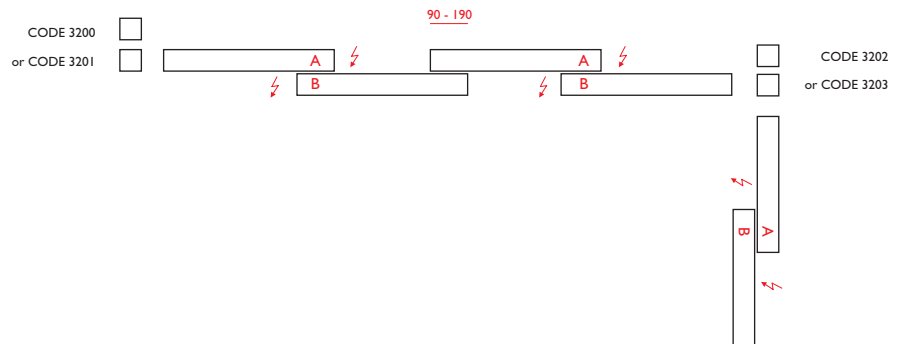
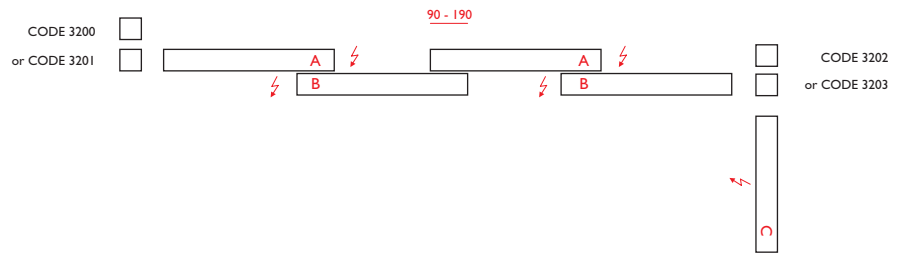
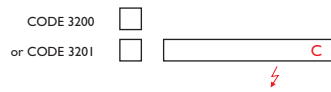

Longline

Eta Installation / Montáž Éta / Montage Eta/ Assemblage Eta / Монтаж Éta

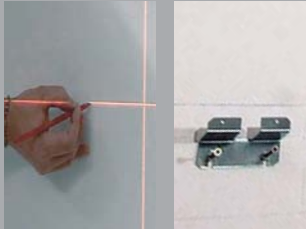

Anchors location

Zaměření kotvěv / Ausrichtung der Anker
Mesures des induits / Анкерные измерения



Corner cutting

Řezání rohu / Eckenzuschneidung
Coupe de l'angle / Нарезка углов



Corner cementing

Lepení rohu / Eckenverklebung
Collage de l'angle / Склеивание углов



Inserted part

Vložený kus / Stückeinbettung
Pièce insérée / Промежуточный кусок

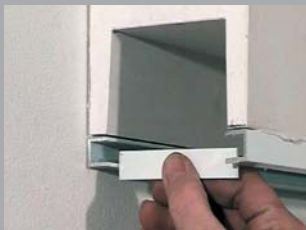

Bottom fillets

Dolní lišty / Untere Leisten
Listels bas / Нижняя планка



Bandage

Bandáž / Bandage
Bandage / Бандаж



Grinding and coating

Broušení a natírání / Schleifen und Anstrich
Taille et peinture / Шлифовка и покраска



Electric equipment holder

Držák el. výzbroj / Elektronisches Vorschaltgerät
Poignée de l'équipement électrique / Держатель электрооборудования



Electric equipment

Elektrická výzbroj / Elektronisches Vorschaltgerät
Équipement électrique / Электротехническое оборудование



Glass dilatation

Dilatace skla / Glasausdehnung
Dilatation de verre / Дилатация стекла



Assembly

Montáž skla / Zusammenstellung von Glas
Assortiment / Сборка



Lighting cornice

Svitící římsa / Leuchtgesims
Moulure lumineuse / Световой карниз

Eta scheme / Schéma Eta / Eta schema / Схема Éta

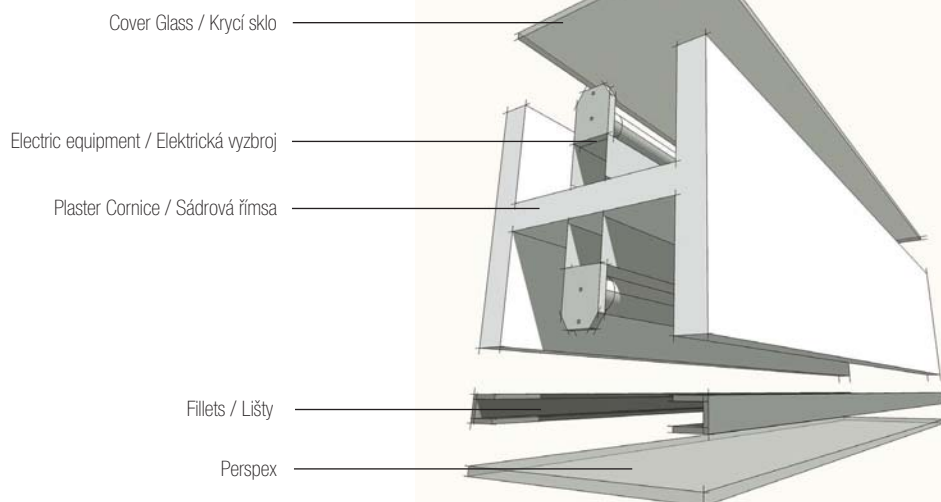



T5 lenghts calculation example / Příklad délek elektrických výzbrojí pro T5
Beispiel der Längenberechnung für T5 / Exemple du calcul des longueurs pour T5 / Пример расчета длины в T5

A + B		1x	2x	3x	4x	5x	6x	C	1x
49W	max mm	2850	5610	8370	11130	13890	16650	49W	1470
	min mm	2750	5310	7870	10430	12990	15550		
54W	max mm	2250	4410	6570	8730	10890	13050	54W	1170
	min mm	2150	4110	6070	8030	9990	11950		
39W	max mm	1650	3210	4770	6330	7890	9450	39W	870
	min mm	1550	2910	4270	5630	6990	8350		
24W	mm	1060	2040	3020	4000	4980	5960	24W	570







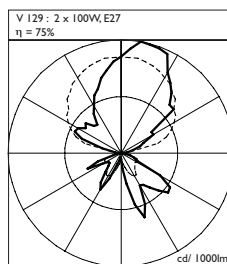
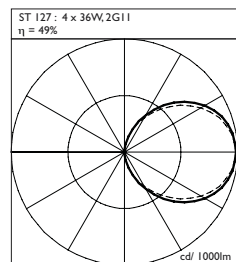
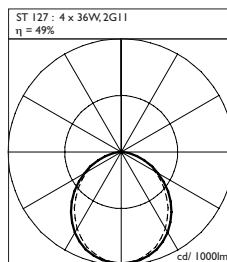
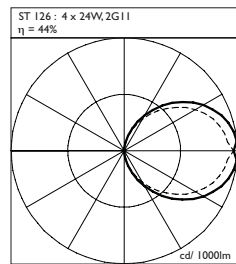
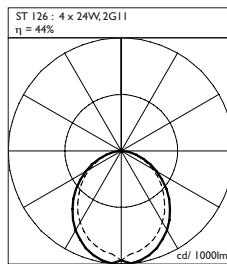
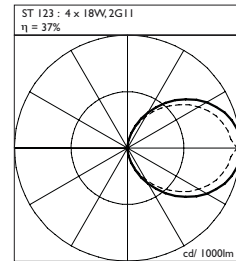
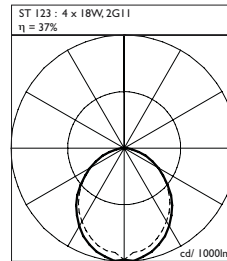
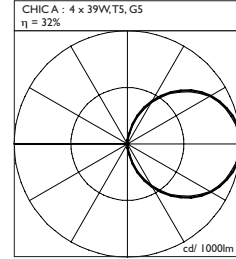
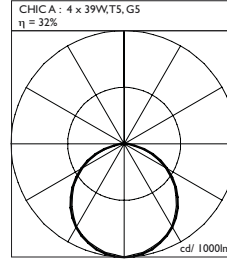
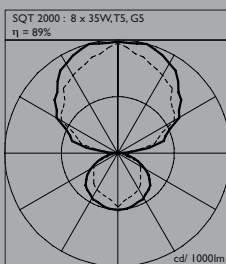
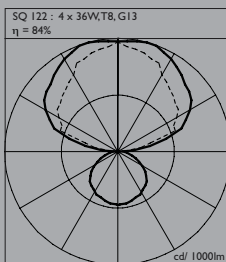
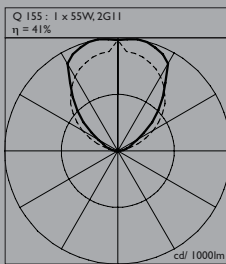
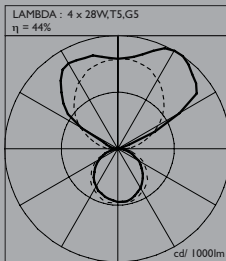
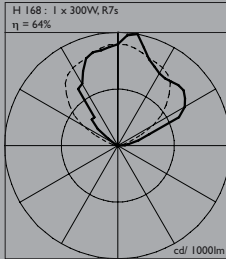







Symbols / Symboly

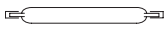
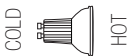

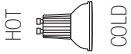
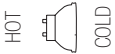

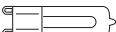

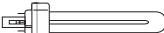
	<p>Wall Light - Indirect and Direct Lighting Nástěnné svítidlo - Nepřímé a přímé osvětlení / Wandleuchte - Indirekte und Direkte Beleuchtung Applique - Éclairage indirect et direct / Светильник на стену - Непрямое и прямое освещение</p>		<p>Safety Glass Bezpečnostní sklo / Sicherheitsglas Verre de sécurité / Безопасное стекло</p>
	<p>Ceiling Light - Indirect and Direct Lighting Stropní svítidlo - Nepřímé a přímé osvětlení / Deckenleuchte - Indirekte und Direkte Beleuchtung Plafonnier - Éclairage indirect et direct / Светильник на потолок - Непрямое и прямое освещение</p>		<p>Perspex Perspex</p>
	<p>Wall Light - Indirect Lighting Nástěnné svítidlo - Přímé osvětlení / Wandleuchte - Indirekte Beleuchtung Applique - Éclairage indirect / Светильник на стену - Непрямое освещение</p>		<p>Net Weight (kg) Čistá hmotnost (kg) / Netto Gewicht (kg) Poids net (kg) / Чистый вес</p>
	<p>Wall Light - Direct Lighting Nástěnné svítidlo - Přímé osvětlení / Wandleuchte - Direkte Beleuchtung Applique - Éclairage direct / Светильник на стену - Прямое освещение</p>		<p>Protection Grade Stupeň ochrany proti vlhkosti / Schutzkennziffer Indice de protection / Коэффициент влагозащиты</p>
	<p>Ceiling Light - Direct Lighting Stropní svítidlo - Přímé osvětlení / Deckenleuchte - Direkte Beleuchtung Plafonnier - Éclairage direct / Светильник на потолок - Прямое освещение</p>		<p>Lamp Included Včetně světelného zdroje / Inkl. Leuchtmittel Source lumineuse compris / С источником света</p>
	<p>Floor Lamp Stojanové svítidlo / Stehleuchte Lampadaire / Торшер</p>		<p>LED diods LED diody</p>
	<p>Minimal ceiling distance (m) Doporučená vzdálenost od stropu (m) / Mindestabstand von der Decke (m) Distance minimale au plafond (m) / Минимальная дистанция от потолка (m)</p>		<p>RGB spectrum RGB spektrum</p>
	<p>Special plaster ecolit Speciální sádra Ecolit / Speziell Gips Ecolit Plâtre spécial ecolith / Специальный гипс эколит</p>		<p>Electric equipment with an electronic ballast Elektrická výzbroj s elektronickým předřadníkem / Elektrische Einheit mit dem elektronischen Vorschaltgerät Équipement électrique avec un ballast électronique / Электрооборудование с электронным балластом</p>
	<p>Aeroceramic Aerokeramika / Aerokeramik L'aérocéramique / Аэрокерамика</p>		<p>Electric equipment with a switch start ballast Elektrická výzbroj s magnetickým předřadníkem / Elektrische Einheit mit dem magnetisches Vorschaltgerät Équipement électrique avec un ballast conventionnel / Электрооборудование с магнетический балластом</p>
	<p>Ceramic Keramika / Keramik Céramique / Керамика</p>		<p>Electric equipment with a dimmable electronic ballast Elektrická výzbroj se stmívatelným elektronickým předřadníkem / Elektrische Einheit mit dem elektronisches Vorschaltgerät - dimmbar / Equipement électrique avec un ballast électronique graduable / Электрооборудование с электронным балластом с регулятором света</p>
	<p>Stainless steel Nerezová ocel / Edelstahl Acier inoxydable / Нержавеющая сталь</p>		<p>Stand-by Lighting Nouzové osvětlení / Notlicht Éclairage de secours / Аварийное освещение</p>
	<p>Glass Sklo / Glas Verre / Стекло</p>		<p>Optional Volitelné / Wahlfrei Éligible / Избирательное</p>
	<p>Polished Stainless Steel Nerezová ocel leštěná / Poliertes Edelstahl Acier inoxydable poli / Нержавеющая сталь полированная</p>		<p>Optional Cover Glass Sandblasted Volitelné - krycí sklo pískované / Wahlfrei - Deckelglas gesandstrahlt Éligible - verre de couverture sablé / Избирательное - стекло перекрытия пескоструйное</p>
	<p>Brushed Stainless Steel Nerezová ocel kartáčovaná / Edelstahl gebürstet Acier inoxydable brossé / Нержавеющая сталь обработанная щеткой</p>		<p>Optional Insect Protecting Device Volitelné - ochrana proti vniknutí hmyzu / Wahlfrei - Schutznetz gegen Insekten Éligible - protection contre insecte / Избирательное - Защита против проникновения насекомых</p>
	<p>Stainless Steel with Decor Nerezová ocel s dekorem / Edelstahl mit Dekor Acier inoxydable avec décor / Нержавеющая сталь с декором</p>		<p>Optional Colour Volitelná barva / Wahlfrei - Farbe Éligible - Couleur a option / Цвет по желанию</p>
	<p>Sandblasted Glass Pískované sklo / Gesandstrahlit Glas Verre sablé / Пескоструйное стекло</p>		<p>Swimming Pool Bazén / Bassin Piscine / Бассейн</p>
	<p>Opal two-ply Glass Dvouvrstvé opálové sklo / Opal Doppelscheibenglas Opal verre a double couche / Глушеное двухслойное стекло</p>		<p>Lightsource's Colour Code Kód barvy světelného zdroje / Leuchtmittelfarbenkode Code de la couleur d'une source lumineuse / Код цвета источника света</p>
	<p>Opal three-ply Glass Trojvrstvé opálové sklo / Opal Dreischiebenglas Opal verre a triple couche / Глушеное трехслойное стекло</p>		

Eulumdata

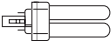
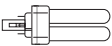

Lightsources / Světelné zdroje

Symbol	Code	W	V	Socket	lm	lm/W	<mm>
	D45	60	230	E14	660	11	75
	A45	60	230	E27	660	11	75
	A60	60	230	E27	710	11,83	105
	T60 SOFT	75	230	E27	840	11	105
	A60	100	230	E27	1380	13,80	105
	SOFT GLOBE G80	60	230	E27	1000	10	
	SOFT GLOBE G95	60	230	E27	890	8,9	
	QT-DE12	100 150 150 300 500	230	R7s R7s R7s R7s R7s	1600 2500 2500 5000 9500	16 17 16 17 19	74,9 74,9 114,2 114,2 114,2
	ES 63	75	230	GU10			62
	ES 50	50	230	GU10			55
	ESD 50	50	230	GZ10			55
	QR-CBC51	20 35 50	12	GU5,3 GU5,3 GU5,3			45 45 45
	QT9-ax	50	230	G4			45
	HALOGEN	25 40	230	G9 G9	260 490	10,4 12,25	43 43
	TC-SL	5		2G7	250	69	85
	TC	9		G23	600	67	167
	TC-L	18 24 36 55		2G11 2G11 2G11 2G11	1200 1800 2900 4800	67 75 80 87	217 320 415 535
	TC-TSE	15 23	230	E27 E27	900 1500	60 66	

Symbol	Code	W	V	Socket	lm	lm/W	<mm>
	TC-D	10		G24d-1	600	60	110
		13		G24d-1	900	69	138
		26		G24d-3	1800	69	172
	TC-DEL	10		G24q-1	600	60	103
		13		G24q-1	900	69	131
		26		G24q-3	1800	69	165
	TC-T	26		Gx24d-3	1800	69	133
	TC-TEL	26		Gx24q-3	2400	69	133
		32		Gx24q-3	2400	75	142
		42		Gx24q-4	2400	76	163
	TC-F	36		2G10	2800	78	217
	T2	8		W 4,3x8,5d	540	68	320
	T2	11		W 4,3x8,5d	750	68	421
	T2	13		W 4,3x8,5d	930	72	523
	T5	8		G5	450	86	288
	T5	14		G5	1200	86	549
	T5	21		G5	1900	91	849
	T5	28		G5	2600	93	1149
	T5	35		G5	3300	95	1449
	T5	24		G5	1750	73	549
	T5	39		G5	3100	80	849
	T5	49		G5	4300	88	1449
	T5	54		G5	4450	83	1149
	T5	80		G5	6150	77	1449
	T8	15		G13	950	63	438
	T8	18		G13	1350	75	590
T8	30		G13	2400	80	895	
T8	36		G13	3350	93	1200	
T8	58		G13	5200	90	1500	
	TL-5C	22		2xG13	1800	81,81	225
	TL-5C	40		2xG13	3200	80	300

Lightsource's Colour / Barva světelného zdroje

827 / 2700 °K

830 / 3000 °K

840 / 4000 °K

Index by code

Index by code / Seznam podle kódů

Code	Page	Code	Page	Code	Page	Code	Page	Code	Page
1010	48	1135	35	1234	30	1320	29	1510	56
1011	48	1136	35	1235	31	1321	29	1511	56
1012	48	1137	35	1236	31	1322	29	1513	56
1020	48	1139	35	1237	31	1330	29	1514	56
1021	48	1140	35	1238	31	1331	29	1516	56
1022	48	1145	35	1240	31	1332	29	1517	56
1023	48	1146	35	1242	31	1335	34	1519	56
1030	48	1147	35	1243	31	1336	34	1520	56
1031	48	1149	35	1246	31	1337	34	1522	56
1032	48	1150	35	1247	31	1338	34	1525	38
1033	48	1151	35	1250	31	1339	34	1526	38
1035	48	1152	34	1251	31	1340	34	1527	38
1037	48	1160	34	1253	31	1341	34	1529	38
1038	48	1161	34	1254	30	1342	34	1530	38
1043	48	1162	34	1260	31	1343	34	1531	38
1044	48	1163	34	1261	31	1345	34	1538	38
1060	48	1170	51	1262	31	1346	34	1541	38
1061	48	1171	51	1263	30	1347	34	1542	38
1070	48	1172	51	1264	30	1348	34	1543	38
1071	48	1173	51	1265	51	1349	34	1545	38
1072	48	1175	51	1266	51	1350	34	1546	38
1075	48	1176	51	1267	51	1351	34	1547	38
1076	48	1177	51	1268	51	1352	34	1550	38
1077	48	1190	47	1270	51	1355	54	1551	38
1078	48	1191	47	1272	51	1356	54	1552	39
1080	48	1192	47	1273	51	1365	54	1553	39
1082	48	1193	47	1276	51	1366	54	1554	39
1083	48	1194	47	1277	51	1370	53	1555	39
1090	50	1195	47	1285	51	1371	53	1557	39
1091	50	1196	47	1286	51	1372	53	1558	39
1092	50	1197	47	1287	51	1380	53	1559	39
1093	50	1198	47	1288	51	1381	53	1560	39
1096	50	1199	47	1295	52	1382	53	1561	39
1098	50	1200	31	1296	52	1383	53	1562	39
1099	50	1201	31	1297	52	1384	53	1563	39
1100	50	1202	31	1298	52	1390	27	1564	39
1110	50	1203	31	1300	52	1391	27	1582	28
1111	50	1204	31	1301	52	1392	27	1583	28
1112	50	1205	31	1302	52	1393	27	1584	28
1113	50	1206	31	1303	52	1395	27	1585	57
1114	50	1213	31	1305	51	1396	27	1587	57
1115	50	1214	31	1305/44	51	1418	54	1590	57
1120	50	1220	31	1306	51	1500	44	1592	57
1121	50	1221	31	1306/44	51	1501	44	1593	28
1125	50	1225	31	1310	52	1502	44	1594	28
1126	50	1226	31	1311	52	1503	44	1595	28
1130	35	1230	31	1312	52	1504	44	1596	28
1131	35	1231	31	1315	52	1505	56	1600	36
1132	35	1232	31	1316	52	1508	56	1601	36
1133	34	1233	30	1317	52	1509	56	1602	36

Index by code / Seznam podle kódů

Code	Page	Code	Page	Code	Page	Code	Page	Code	Page
1603	36	1823	55	3162	84	4115	62	5002	10
1604	36	1861	55	3163	84	4116	62	5501	12
1605	36	1862	55	3170	84	4201	58	5502	12
1606	36	1863	55	3171	84	4202	58	5503	13
1623	71	1890	55	3172	84	4203	58	5504	13
1625	71	1891	55	3173	84	4211	58	5505	13
1626	71	1892	55	3180	84	4212	58	5508	14
1627	71	1910	55	3181	84	4213	58	5509	14
1628	71	1911	55	3182	84	4221	59	5510	15
1629	71	1912	55	3183	84	4222	59	5511	15
1630	71	1920	55	3190	84	4223	59		
1631	71	1921	55	3191	84	4301	60	1221.01	72
1632	71	1922	55	3192	84	4302	60	1222.01	72
1654	57	3001	82	3193	84	4303	60	1223.01	73
1655	57	3002	82	3200	84	4311	60	1224.01	73
1656	57	3003	82	3201	84	4312	60	1225.01	74
1659	71	3005	82	3202	84	4313	60	1226.01	74
1661	71	3006	82	3203	84	4321	61	1227.01	75
1662	71	3008	82	3204	84	4322	61	1228.01	75
1663	71	3009	82	4007	69	4323	61	1229.01	72
1664	71	3010	82	4008	69	4401	19	1230.01	74
1665	71	3011	81	4009	69	4402	19	1321.01	72
1666	71	3022	80	4010	68	4520	18	1322.01	72
1670	71	3023	80	4011	68	4530	21	1325.01	74
1671	71	3024	80	4012	68	4531	21	1326.01	74
1710	46	3030	83	4014	68	4540	20	1329.01	72
1711	46	3031	83	4020	68	4541	20	1330.01	74
1718	46	3032	83	4021	68	4550	18	1420.01	76
1728	47	3033	83	4022	68	4567	18		
1729	47	3034	83	4024	68	4570	40	T1204K	77
1750	32	3035	83	4030	68	4571	40	T1215K	77
1751	32	3100	80	4031	68	4572	40	T1230K	77
1752	32	3120	84	4032	68	4580	42	T1260K	77
1753	32	3121	84	4034	68	4590	42	T12100K	77
1754	32	3122	84	4040	68	4600	26		
1760	32	3123	84	4041	68	4610	49		
1761	32	3130	84	4042	68	4615	66		
1762	32	3131	84	4044	68	4616	66		
1763	32	3132	84	4050	70	4617	66		
1764	32	3133	84	4051	70	4618	66		
1800	28	3140	84	4052	70	4619	66		
1801	28	3141	84	4053	70	4620	66		
1802	28	3142	84	4054	70	4621	66		
1803	28	3143	84	4055	70	4622	66		
1804	28	3150	84	4056	70	4623	66		
1811	55	3151	84	4060	70	4630	08		
1812	55	3152	84	4101	62	4631	08		
1813	55	3153	84	4102	62	4632	09		
1821	55	3160	84	4111	62	4633	09		
1822	55	3161	84	4112	62	5001	10		

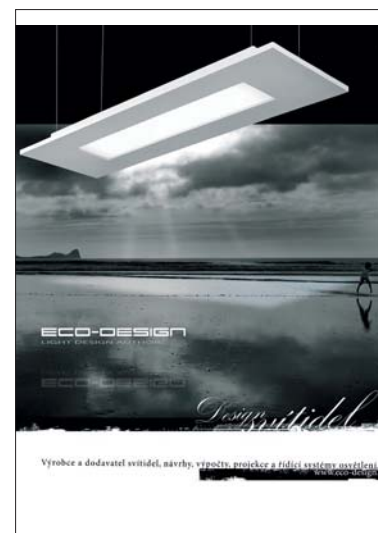

ECO-DESIGN Poster
Plakát ED / Poster ED / Affiche ED / Плакат экодизайн

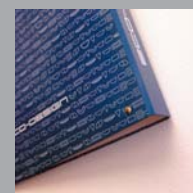
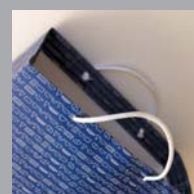

Exhibition boards / Výstavní panely / Ausstellungstafel / Panneau d'exposition / Стенд

Type A - dimensions 1500 x 1200 x 2440 mm

Typ A - rozměry / Typ A - formate / Type A - dimensions / Тип А - Размеры

Type B - dimensions 2500 x 1000 x 2540 mm

Typ B - rozměry / Typ B - formate / Type B - dimensions / Тип В - Размеры



Type C - dimensions 2000 x 1200 x 74 mm

Typ C - rozměry / Typ C - formate / Type C - dimensions / Тип С - Размеры



Marketing Tools / Marketingové nástroje / Marketinginstrumente / Outils marketing / Маркетинговые инструменты

ECO-DESIGN "Bulb" with Slivovice traditional czech spirit
Slivovice ED / Slivowitz ED / Bouteille d'eau de vie ED / Сливовица

ECO-DESIGN Bag
Taška ED / Tasche ED / Sac ED / Сумка ЭД

ECO-DESIGN Bell
Zvoneček ED / Glöckchen ED / Clochette ED / Белл ЭД

ECO-DESIGN Folder
Pořadač ED / Ordner ED / Classeur ED / Скоросшиватель ЭД

ECO-DESIGN Flag
Vlajka ED / Flagge ED / Drapeau ED / Флаг ЭД

ECO-DESIGN Label
Štítek ED / Schildchen ED / Vignette ED / Табличка ЭД

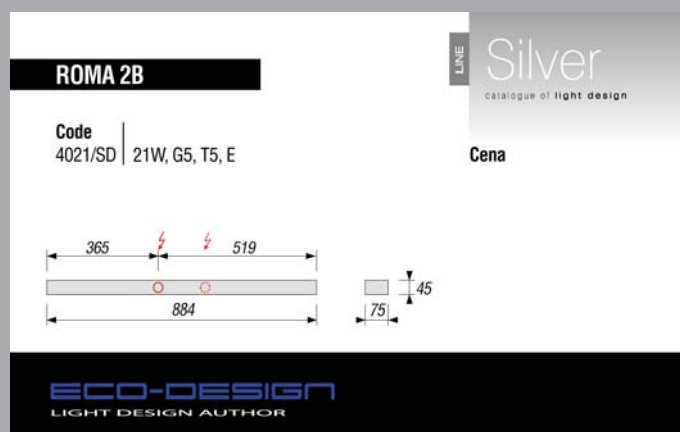

Note :

All information in this catalogue is without guarantee, replaces all preceding information and can be modified at any time. We reserve the right to design modification. The measurement specifications refer to approximate dimensions. We reserve ownership rights to this catalogue.

Poznámka :

Veškerý obsah tohoto katalogu je bez záruky, nahrazuje všechny předešlé informace a může být kdykoliv pozměněn. Vyhrazujeme si právo na změny designu. Rozměrové specifikace se vztahují na průměrné hodnoty. Vyhrazujeme si vlastnická práva k tomuto katalogu.

Bemerkung :

Der gesammte Inhalt dieses Kataloges ist ohne Haftung, ersetzt alle vorherigen Informationen und kann jederzeit geändert werden. Wir behalten uns das Recht auf Designänderungen vor. Maßspezifikationen beziehen sich auf Durchschnittswerte. Wir behalten uns Urheberrechte für den Katalog vor.

Note :

Le contenu total de ce catalogue est sans garantie. Il peut remplacer tous les renseignements précédents en avoir le droit exclusif de les modifier à tout moment. Nous réservons le droit concernant le changement du design. Les spécifications dimensionnelles se réfèrent aux valeurs moyennes. Nous réservons également le droit pour ce catalogue.

Примечание :

Все содержимое этого каталога предлагается без гарантии, заменяет все предыдущие информации и может быть изменено в любое время. Мы оставляем за собой право на изменение дизайна. Размеры предлагаются средних параметров. Мы оставляем за собой право собственности на каталог.



ECO-DESIGN
Nerudova 36,
37004 České Budějovice
Czech Republic
EU 

Tel./Fax: +420 387 310 419

info@eco-design.eu

WWW.ECO-DESIGN.EU